

ELL-220-A



Installation Instructions

ELL-220-A End of line lamp kit
for use with BARTEC BPL trace heaters

Consignes d'installation

Kit de lampes de fin de ligne ELL-220-A
à utiliser avec les câbles chauffants de type BARTEC BPL

Table of contents	
Safety	2
Overview	3
Compatibility	3
Certifications / Approvals	3
Technical data	3
Maximum pipe / workpiece temperature	3
Kit contents	4
Accessories	5
Installation	6
Preparation	6
Maximum heating circuit length	6
Required tools / equipment	7
Cautions and warnings	7
Nodes	8
Trace heater preparation	8
Trace heater routing	9
Fastening	10
Preparation of the trace heater	11
Installation of the heat shrink tubes	14
Wiring	17
Application of the pipe insulation	18
Tests and commissioning	19
Troubleshooting	20
Alternate method for node location	21
Product charts for node location	23

Safety

For safe installation of the ELL-220-A End of line lamp kit the technical requirements and instructions given in this manual must be followed.

⚠ WARNING

Risk of fire or electrical shock. Follow these guidelines to avoid personal injury or material damage.

- All electrical systems and installations must comply with BARTEC GmbH requirements and be installed in accordance with the relevant electrical codes and any other applicable national and local codes.
- BARTEC GmbH, the US and Canadian electrical codes require ground fault protection to be provided for all trace heating circuits.
- According to CSA-approval use only BPL trace heaters for connection to ELL-220-A End of line lamp kit.
- Installation and Maintenance is allowed to persons who are trained in electrical engineering only.
- Install the connection kit, trace heaters and end seals carefully.
- Use the trace heater in accordance with the intended purpose and strictly comply with the operational data specified in section *Technical Data*.
- The bending radius of the trace heater must be at least 1" (25 mm).
- Any defective component of the kit must be replaced before installation.
- To avoid short circuits, do not connect the trace heater bus wires together.
- Keep all components and the trace heaters dry before and during installation.
- Keep these instructions for future reference. If applicable, leave them with the end user.
- De-energize before installation or servicing.
- Use only original BARTEC accessories.

NOTICE

The following instructions are provided in English only. Refer to www.bartec.us for the French version.

Sécurité

Afin de garantir la sécurité lors de l'installation et de l'utilisation du Kit de lampes de fin de ligne ELL-220-A, il est impératif de respecter les exigences ainsi que les consignes techniques mentionnées dans le présent manuel.

⚠ AVERTISSEMENT

Risque d'incendie ou d'électrocution. Suivez ces consignes pour éviter toute blessure ou dommage matériel.

- Tous les systèmes et installations électriques doivent satisfaire aux exigences imposées par la société BARTEC GmbH et doivent être installés conformément aux normes électriques en vigueur ainsi qu'aux autres prescriptions nationales et locales applicables.
- La société BARTEC GmbH ainsi que les normes électriques américaines et canadiennes imposent une protection contre les défauts à la terre pour tous les circuits de traçage électrique.
- La certification CSA s'applique uniquement à l'utilisation des câbles chauffants de type BPL à être connectés aux embouts d'étanchéité faciles d'accès Kit de lampes de fin de ligne ELL-220-A
- L'installation et la maintenance sont réservées aux personnes ayant une formation en électrotechnique.
- La pose du kit de raccordement, des câbles chauffants et des embouts d'étanchéité doit être réalisée avec soin.
- Utilisez le câble chauffant conformément à l'usage prévu et en respectant les caractéristiques de fonctionnement spécifiées à la section *Caractéristiques techniques*.
- Le rayon de courbure du câble chauffant ne doit pas être inférieur à 1" (25 mm).
- Tout élément défectueux dans le kit doit être remplacé avant l'installation.
- Pour éviter un court-circuit, ne jamais raccorder ensemble les deux conducteurs du câble chauffant.
- Conservez tous les éléments et les câbles chauffants au sec avant et pendant l'installation.
- Conservez ces instructions pour un usage ultérieur. Le cas échéant, remettez-les à l'utilisateur final.
- Mettez le système hors tension avant toute installation ou opération de maintenance.
- Utilisez exclusivement des pièces et accessoires d'origine BARTEC.

AVIS

Les instructions qui suivent sont fournies en anglais uniquement. Veuillez vous référer au site www.bartec.us pour la version française.

Overview

This manual covers the installation and operation of the BARTEC ELL-220-A End of line lamp kit.

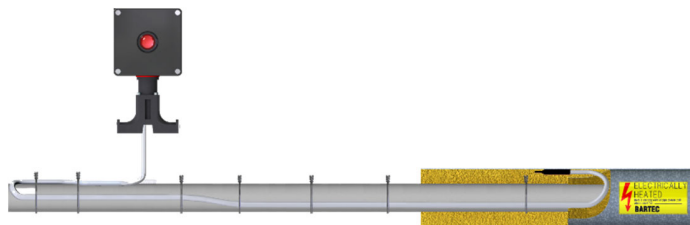

The trace heating system uses a parallel trace heater. Its fixed specific resistance offers a constant power output irrespective of the ambient temperature. The aluminum outer jacket ensures maximum mechanical strength.

The trace heaters are fixed equipment heating systems for pipes in ordinary and hazardous areas. The trace heater can be cutted and installed to any required length (up to the maximum heating circuit length as shown on page 6).

NOTICE

For temperatures above 392°F (200°C), the stand needs to be mounted off the pipe.

Compatibility

The manual applies for the following trace heaters:

- BARTEC BPL

The following terms describe the parts of the trace heater within these instructions:

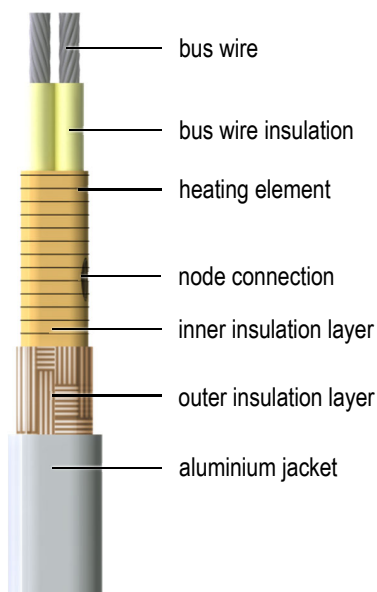

Certifications / Approvals

BARTEC GRP Junction Box:



Class I, Div. 2, Groups A, B, C, D
Class II, Div. 2, Groups E, F, G
Class III

Connection Kit:



Class I, Div. 2, Groups A, B, C, D
Class II, Div. 2, Groups F, G
Class III Div. 2
Type 4X

Technical data

Ambiet temperature range		-40 to 104°F (-40 to 40°C)
Maximum exposure temperature (BPL)	<i>continuous</i>	-40 to 644°F (-40 to 350°C)
	<i>intermittent</i>	-40 to 797°F (-40 to 425°C)
Minimum installation temperature		-40°F (-40°C)
Power supply		0 to 277 V AC
Trace heater output		5 to 20 W/ft (15 to 70 W/m)
Heater dimensions	<i>outer dimensions</i>	0.42" x 0.3" (10.7 x 7.7 mm)
	<i>bus wires</i>	12 AWG (3 mm ²)
Minimum bending radius		1" (25 mm)
		Do not bend on the narrow axis.
Max. power conductor size		10 AWG (6 mm ²)
Terminals		Spring clamp Ex e,
		2x2 line,
		1x2 PE
Ingress protection		NEMA Type 4X / IP66 according to IEC 60529

Maximum pipe / workpiece temperature¹











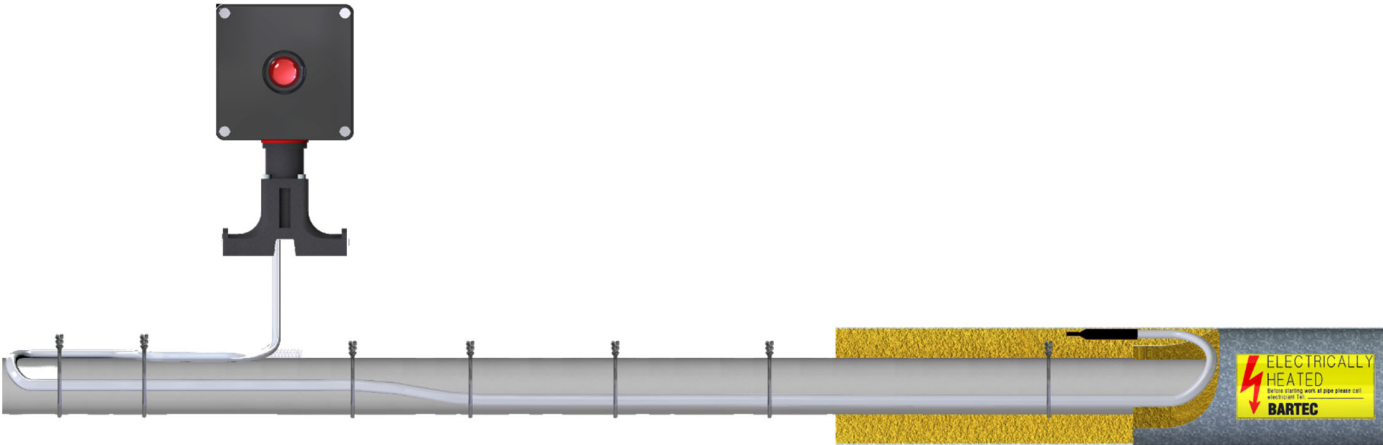

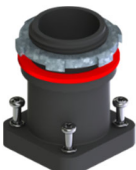
	T5	T4	T3	T2	T1	SAFE ²
5BPL-AL	97 °F (36 °C)	160 °F (71 °C)	320 °F (160 °C)	552 °F (289 °C)	662 °F (350 °C)	662 °F (350 °C)
10BPL-AL	52 °F (11 °C)	82 °F (28 °C)	212 °F (100 °C)	475 °F (246 °C)	613 °F (323 °C)	613 °F (323 °C)
15BPL-AL	-	-	102 °F (39 °C)	352 °F (178 °C)	529 °F (276 °C)	529 °F (276 °C)
20BPL-AL	-	-	-	176 °F (80 °C)	365 °F (185 °C)	365 °F (185 °C)

¹ Applies for 230 V, for 277 V applications contact your local BARTEC representative for assistance. Surface temperature limits in accordance with EN60079.

² Surface temperature limited by materials of construction (withstand temperature)

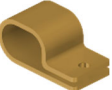
Kit contents

The following table lists the kit contents of the ELL-220-A End of line lamp kit:

 <p style="text-align: center;">ELL-220-A End of line lamp kit</p>				
 <p style="text-align: center;">1 x Cover for junction box incl. 4 fixing screws</p>	 <p style="text-align: center;">1 x Junction box with connection terminals "A" boxes 4.8" x 4.7" (122 x 120 mm)</p>	 <p style="text-align: center;">1 x Top unit of the mounting stand incl. seal ring and lock nut</p>	 <p style="text-align: center;">1 x Base unit of the mounting stand</p>	
 <p style="text-align: center;">1 x Inner heat shrink tube for end termination</p>	 <p style="text-align: center;">1 x Outer heat shrink tube for end termination</p>	 <p style="text-align: center;">2 x Heat shrink tube for bus wires</p>	 <p style="text-align: center;">1 x Outer heat shrink tube for bus wires</p>	
 <p style="text-align: center;">1 x Bonding clip</p>	 <p style="text-align: center;">1 x Bonding jumper for bonding clip</p>	 <p style="text-align: center;">1 x Fixing screw for bonding clip ISO 1207, M4x10</p>	 <p style="text-align: center;">1 x Washer ISO 7089, M4</p>	 <p style="text-align: center;">1 x Nut ISO 4032, M4</p>

Accessories

The following accessories are available for the ELL-220-A End of line lamp kit:

	<p>BPL on pipe power termination and end seal kit</p> <p>spare parts kit for replacement of damaged or lost parts</p>	<p>Catalog No.: HSK-D5-A Order No.: 440424 Part No.: 27-59HZ-EC010001</p>
--	--	---

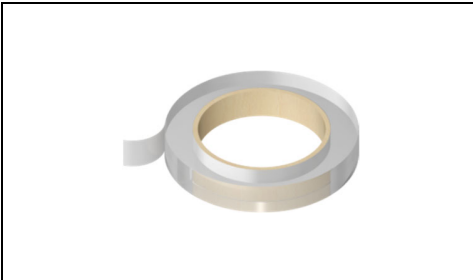
	<p>Glass cloth tape</p> <p>for attaching self-regulating trace heaters on all pipes including stainless steel / required during preparation of power limiting trace heaters</p> <p>12 mm x 50 m per roll</p> <p>Minimum installation temperature (dry surface): -10 °C Maximum withstand temperature: 200 °C</p>	<p>Catalog No.: GT-164 Order No.: 392328 Part No.: 02-5500-0047</p>
--	---	---

Tip: Refer to the following table to estimate the required number of tape rolls for your installation (for attaching trace heaters on pipes only)

Pipe diameter DN (inch)	DN8 (1/4")	DN15 (1/2")	DN20 (3/4")	DN25 (1")	DN32 (1 1/4")	DN40 (1 1/2")	DN50 (2")	DN65 (2 1/2")	DN80 (3")	DN100 (4")	DN150 (6")	DN200 (8")	DN250 (10")	DN300 (12")	DN350 (14")	DN400 (16")	DN450 (18")	DN500 (20")	DN600 (24")
Required no. of tape rolls per 30 m of piping	1	1	1	1	2	2	2	3	3	4	5	7	9	10	11	12	14	15	18

	<p>Stainless steel pipe straps</p> <p>stainless steel, for attaching mounting stands on pipes etc. No special tooling required.</p>	<p>for pipe \varnothing up to 3" / DN80: Catalog No.: PC-1 Order No.: 435727</p> <p>for pipe \varnothing up to 10" / DN250: Catalog No.: PC-2 Order No.: 435729</p>
--	--	---

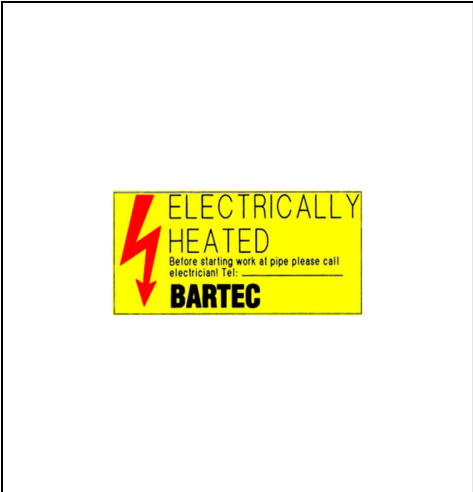
	<p>Electrically traced warning label</p> <p>Warning label for trace heater circuits</p> <p>Recommended: electrical warning label every 3 m on the outside of the thermal cladding on a clearly visible place.</p> <p>Packaged in rolls of 100 pcs.</p>	<p>German: Catalog No.: HTWL-DE Order No.: 113450 Part No.: 05-2144-0046</p> <p>English: Catalog No.: HTWL-EN Order No.: 113550 Part No.: 05-2144-0047</p> <p>French: Catalog No.: HTWL-FR Order No.: 120300 Part No.: 05-2144-0703</p> <p>Russian: Catalog No.: HTWL-RU Order No.: 207439 Part No.: 05-2144-0860</p>
--	---	---

Installation

Preparation

Before installing any electric trace heating, the person installing must check if the trace heating has been designed and planned correctly. It is particularly essential to verify the following points:

- complete project planning documentation, operating instructions and installation instructions.
- correct selection of the trace heater and accessories with respect to:
 - calculation of heat losses
 - max. permissible operating temperature
 - max. permissible ambient temperature
 - temperature class (for hazardous locations)
 - heating circuit length

Before installing, make sure that all piping and equipment is properly installed and pressure tested.

Maximum heating circuit length

The following table shows the maximum circuit lengths in ft (m) for the different BPL trace heater types with standard circuit breaker amperages. Breaker sizing should be based on the National Electrical Code, Canadian Electrical Code or any other local or applicable code. The values apply for a volt drop variation of max. 10 %.

Trace heater type	Start-up temperature in °F (°C)	Maximum heating circuit length in ft. (m)											
		Operating Voltage: 120 V AC (.BPL1-AL only)			Operating Voltage: 208 Vac (.BPL2-AL only)			Operating Voltage: 240 V AC (.BPL2-AL only)			Operating Voltage: 277 Vac (.BPL2-AL only)		
		20 A	30 A	40 A	20 A	30 A	40 A	20 A	30 A	40 A	20 A	30 A	40 A
5BPL.-AL	+50 (+10)	291 (90)	291 (90)	291 (90)	518 (160)	518 (160)	518 (160)	567 (175)	567 (175)	567 (175)	640 (195)	640 (195)	640 (195)
	0 (-18)	275 (85)	275 (85)	275 (85)	502 (155)	502 (155)	502 (155)	550 (170)	550 (170)	550 (170)	623 (190)	623 (190)	623 (190)
	-40 (-40)	259 (80)	259 (80)	259 (80)	470 (145)	470 (145)	470 (145)	518 (160)	518 (160)	518 (160)	607 (185)	607 (185)	607 (185)
10BPL.-AL	+50 (+10)	178 (55)	210 (65)	210 (65)	324 (100)	356 (110)	356 (110)	340 (105)	405 (125)	405 (125)	328 (100)	443 (135)	443 (135)
	0 (-18)	162 (50)	194 (60)	194 (60)	308 (95)	340 (105)	340 (105)	324 (100)	388 (120)	388 (120)	322 (98)	427 (130)	427 (130)
	-40 (-40)	146 (45)	178 (55)	178 (55)	292 (90)	324 (100)	324 (100)	307 (95)	372 (115)	372 (115)	315 (96)	410 (125)	410 (125)
15BPL.-AL	+50 (+10)	121 (37)	162 (50)	162 (50)	194 (60)	275 (85)	275 (85)	246 (75)	344 (105)	344 (105)	203 (62)	322 (98)	344 (105)
	0 (-18)	113 (35)	152 (47)	152 (47)	185 (57)	266 (82)	266 (82)	230 (70)	328 (100)	328 (100)	194 (59)	308 (94)	328 (100)
	-40 (-40)	108 (33)	145 (45)	145 (45)	178 (55)	259 (80)	259 (80)	213 (65)	312 (95)	312 (95)	190 (58)	302 (92)	312 (95)
20BPL.-AL	+50 (+10)	85 (26)	131 (40)	131 (40)	146 (45)	227 (70)	227 (70)	171 (52)	275 (85)	275 (85)	148 (45)	230 (70)	302 (92)
	0 (-18)	79 (24)	125 (38)	125 (38)	136 (42)	217 (67)	217 (67)	164 (50)	259 (80)	259 (80)	141 (43)	223 (68)	289 (88)
	-40 (-40)	72 (22)	118 (36)	118 (36)	130 (40)	211 (65)	211 (65)	157 (48)	256 (78)	256 (78)	135 (41)	217 (66)	282 (86)

Required tools / equipment

The following tools and equipment are required for installation of the ELL-220-A End of line lamp kit:

- Flat screwdriver
- Cross-head screwdriver
- Electricians screwdriver
- Wire cutters
- Utility knife
- Tape measure
- Heat gun
- Needle nose pliers
- Multimeter



- BARTEC GT-108 Glass cloth tape

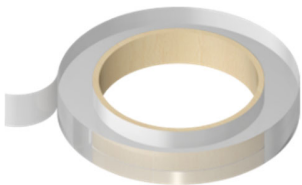

1

Cautions and warnings

WARNING

Risk of fire or electrical shock. De-energize all power circuits before installation or servicing. Always use ground fault equipment protection with the trace heating system.

AVERTISSEMENT

Risque d'incendie ou d'électrocution. Mettre tous les circuits électriques hors tension avant toute installation ou opération de maintenance. Toujours utiliser un dispositif de protection contre les défauts à la terre au sein du système de traçage électrique.

- Double-check that all power circuits are de-energized before you begin your work.
- Make sure that you do not exceed the maximum heating circuit length for the trace heater type you use.

2

Nodes

BPL trace heaters use a heating element that is wound around the inner insulation. To ensure power supply, it alternately touches the bus wires at fixed intervals. These contact points are called nodes. They represent the limits of a heating zone.

The position of the nodes is marked by asterisks at the beginning of the product identification string: i.e. **** BARTEC® @ 5BPL1-AL ...



When the trace heater is cut within a heating zone, this zone will remain cold.

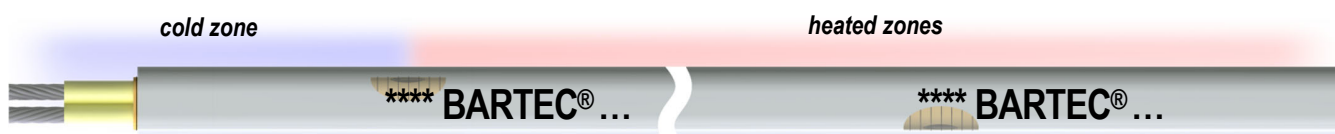

3

Trace heater preparation

⚠ WARNING

Risk of short circuit and/or material damage. Keep the trace heater ends dry before and during installation.

⚠ AVERTISSEMENT

Risque de court-circuit et/ou de dommages matériels. Conservez les extrémités du câble chauffant au sec avant et pendant toute la durée de l'installation. Respectez les indications fournies dans le guide de conception du système de traçage.

- Unroll the required trace heater in a straight line. Do not cut the trace heater yet.
- Do not bend or pinch the trace heater, or pull it over sharp edges.

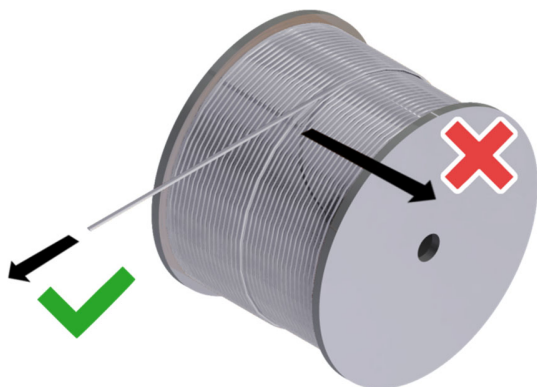

4

- Before cutting the trace heater, measure the distance from the trace heater end to the first node marker.
- Note the measured distance.

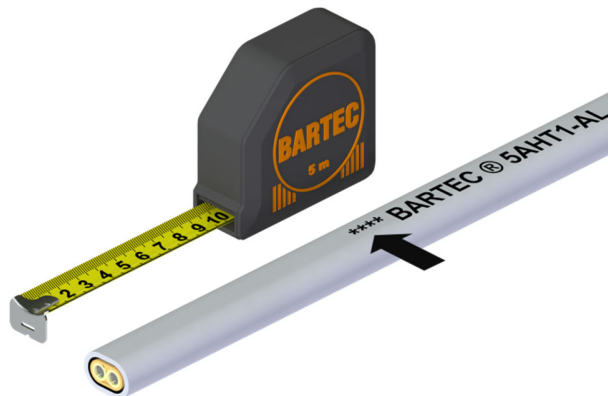

If you cannot find the node markers, refer to section Alternate method for node location on page 21.

5

- Make sure that the distance to the first node is:
 - at least 18" (460 mm) for the trace heater end facing towards the power connection equipment
 - at least 12" (300 mm) for the trace heater end facing towards the end seal

This ensures that the connection equipment will be protected from excessive heat.

- Cut off the trace heater ensuring a straight cut.

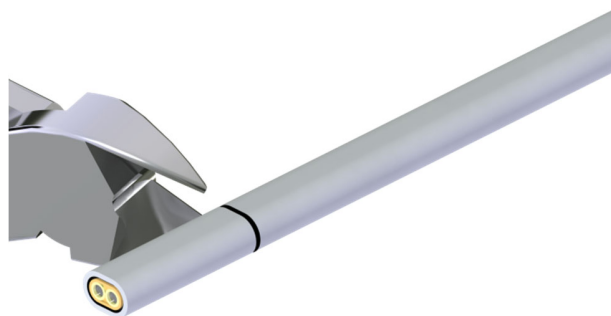

for power connection:

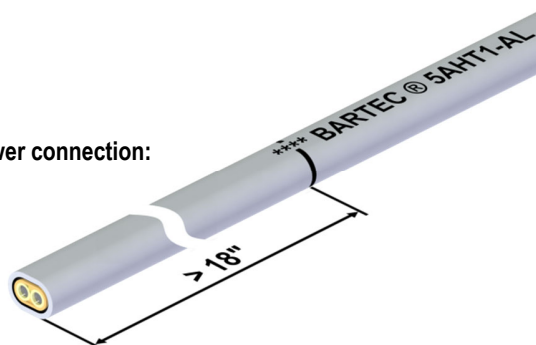

for end seal:

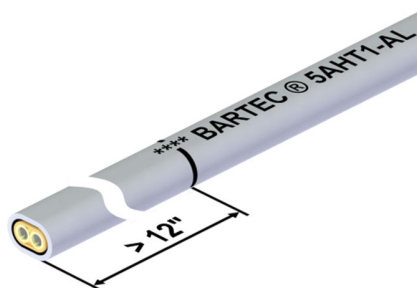

6

Trace heater routing

WARNING

Risk of fire, injury and/or property damage. Observe the following instructions when routing BPL trace heaters.

AVERTISSEMENT

Risque d'incendie, de blessures et/ou de dommages matériels. Suivez les consignes suivantes pour la pose des cables chauffants de type BPL.

- Install the trace heater in a straight line along the pipe. This saves time, helps to avoid installation mistakes and prevents damage to the trace heater during the thermal insulation work.



- Never step on or drive over the trace heater. Do not use it as a loop for stepping on.
- When installing allow for an additional length of trace heater for assembling splice connections, tee branches, end seals etc. (ap-prox. 1.6 ft (0.5 m) for each).
- Do not cross, overlap, or group the trace heaters.

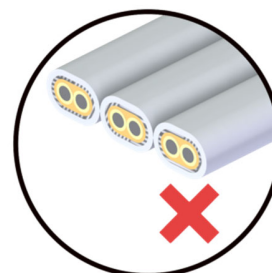
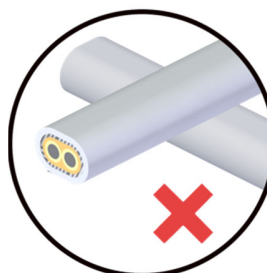
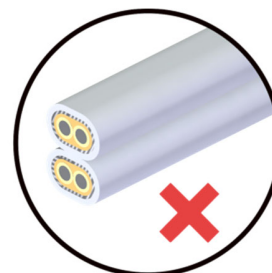
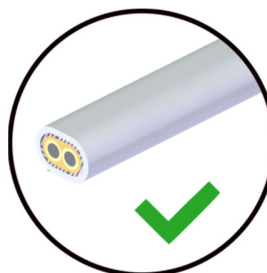

7

- When routing trace heaters on bends, observe the minimum bending radius of 1" (25 mm).
- Do not bend the trace heater on the narrow axis.

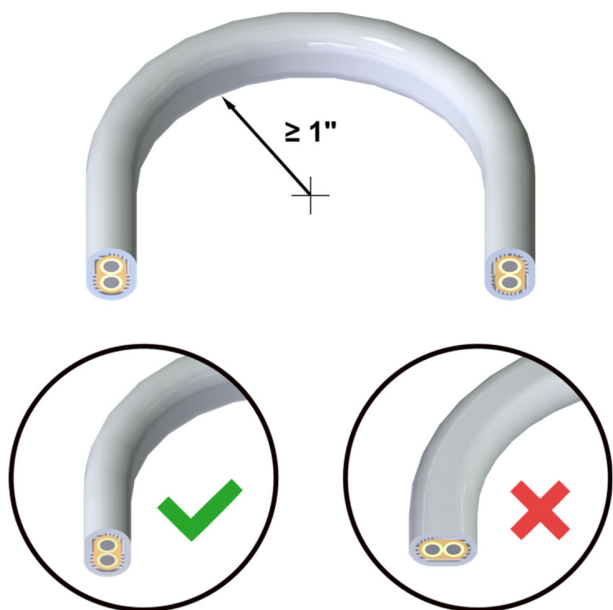

8

Fastening

Select the correct fastening material:

- Always use fastener that suits the expected temperatures.
- Preferably use soft stainless tie wire or stainless steel bands.



10

- Preferably install the trace heater in the lower half of the pipe, **but not on the lowest point**. This prevents mechanical damage and allows for better heat distribution.
- If you use multiple trace heaters, position them with an offset of 90°.

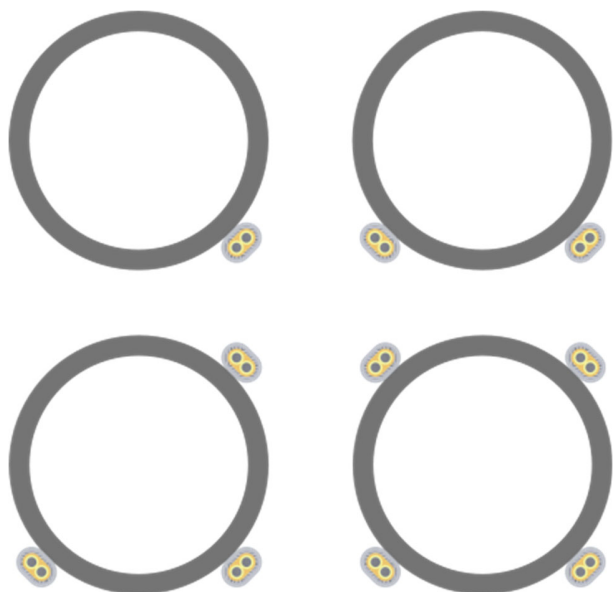

9

- Fasten the trace heater on the pipe at intervals of a maximum of 18" (450 mm).

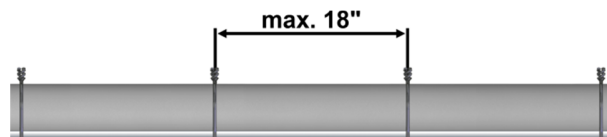

NOTICE

In order to ensure good heat transfer the trace heater should have a flat, flush fit over the whole length. If necessary, reduce the distances between the fixing points.

AVIS

Pour assurer une bonne conduction thermique, le câble chauffant doit être posé bien à plat et bien au contact de la tuyauterie sur toute la longueur. Au besoin, réduisez l'écartement entre les points d'attache.

11

Preparation of the trace heater

For splice connections the following instructions apply for both trace heaters.

- Pass the trace heater through the base unit of the mounting stand.
- Do not fix the mounting stand on the unistrut yet.



12

- Slide the trace heater grommet onto the trace heater and into the seal seat.
- Slide the blind plug into the free seal seat.
- Make sure that the trace heater stands out approximately 10" (25 cm). This makes cable preparation easier.

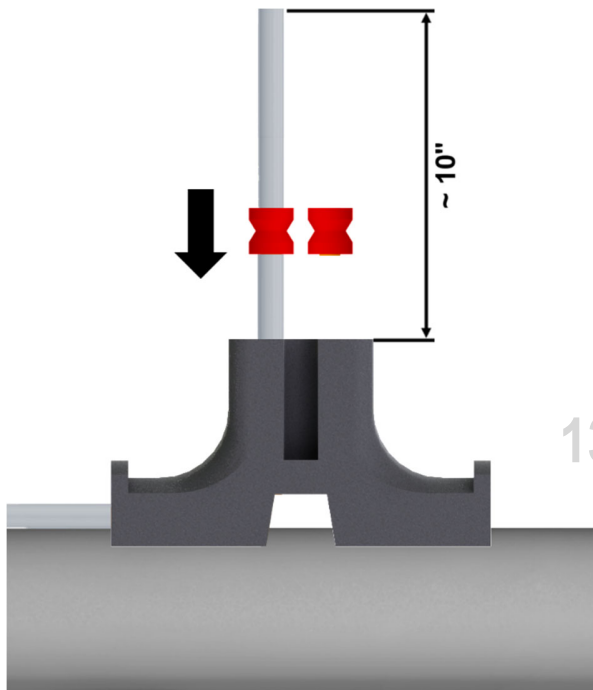

13

- Slide the top unit of the mounting stand over the trace heater.
- Slightly tighten the 4 fixing screws using a 3 mm hex wrench. Do not tighten them fully yet to allow the trace heater to be moved.

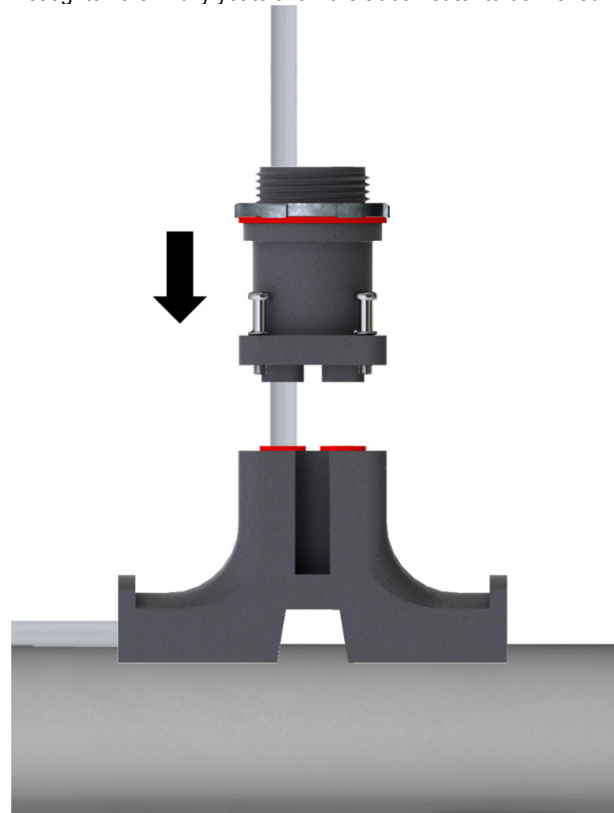

14

- Score around the aluminium jacket at 5 3/4" (145 mm) from the end of the trace heater.

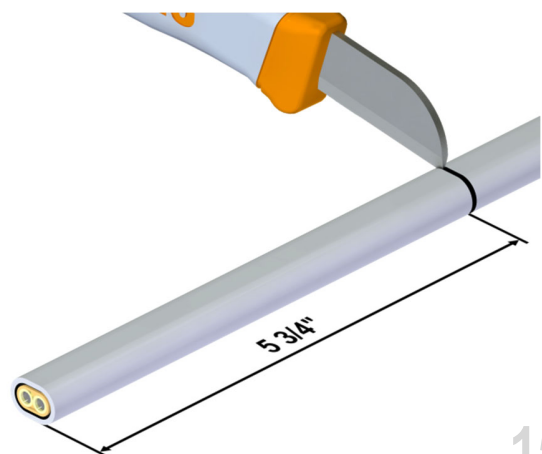

15

- Gently bend the aluminium jacket up and down at the scoring line until the aluminium jacket separates.

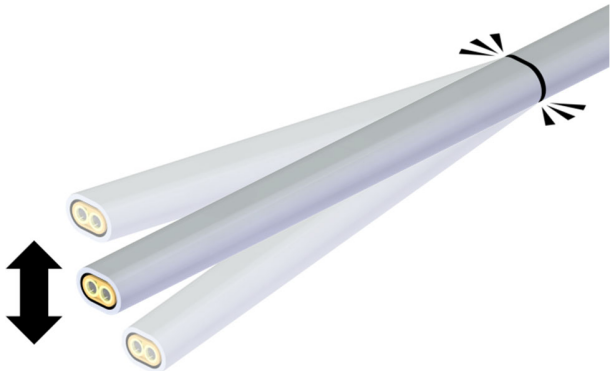

16

- Slide the aluminium jacket from the trace heater.

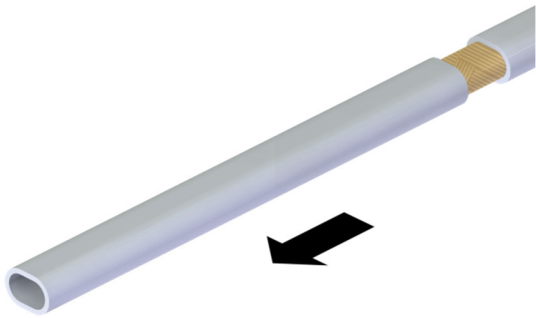

17

- Place 1 wrap of glass cloth tape over the insulation jacket next to the aluminium jacket.

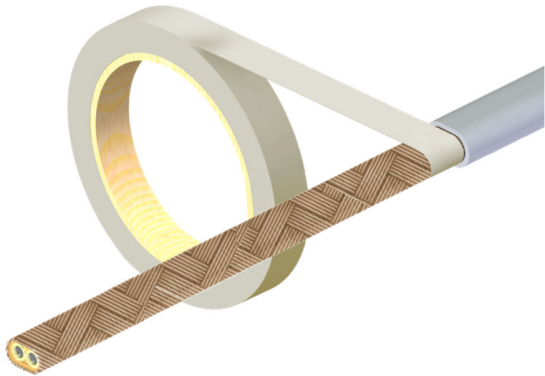

18

- Unwrap the outer insulation layer and cut it off.

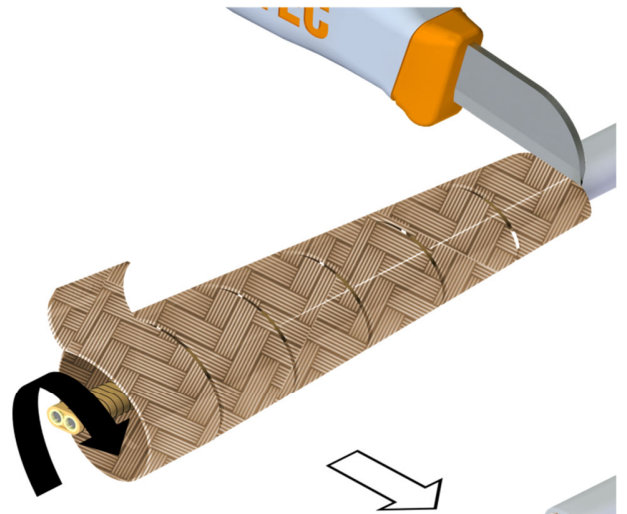

19

- Unwind the heating element and cut it off.

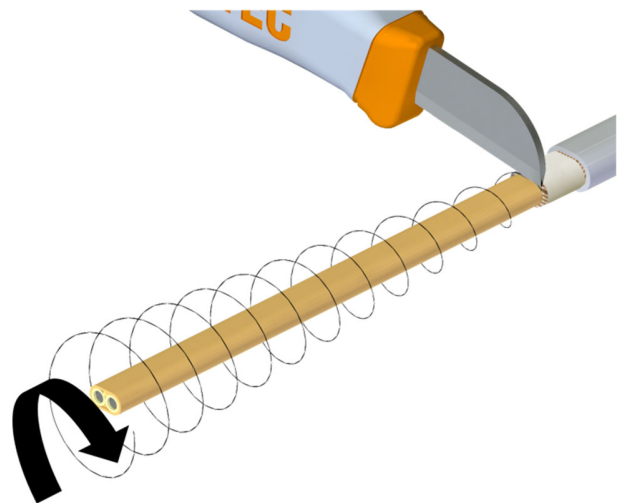

20

- Unwrap the inner insulation layer and cut it off.

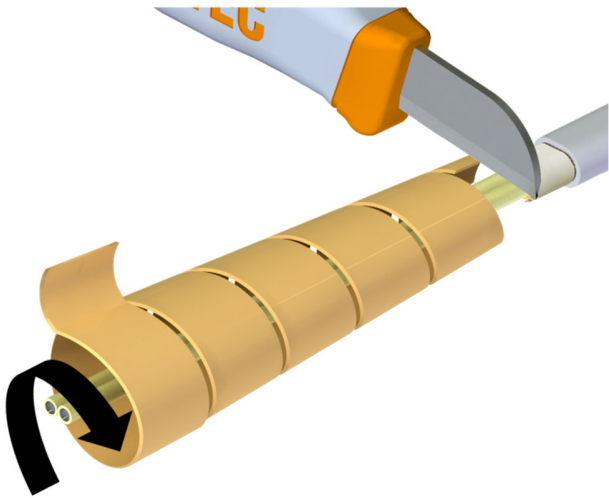

21

- Unwrap the exposed bus wire insulation and cut it off.

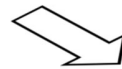
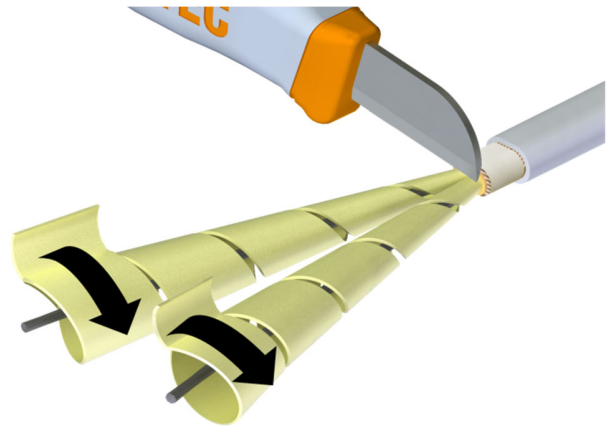

22

- Make sure that all bus wires are intact and not nicked or damaged.

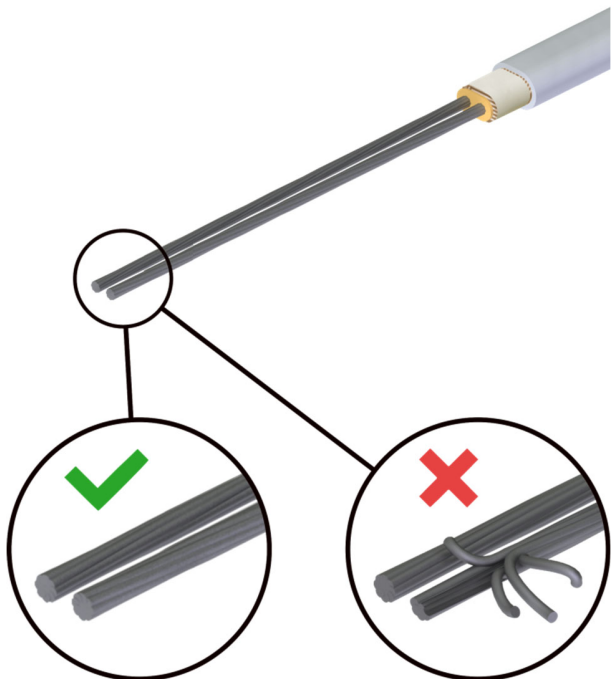

23

Installation of the heat shrink tubes

- Slide the bus wire heat shrink tubes (*length: 4" (100 mm); diameter: 1/4" (6 mm)*) onto the bus wires.

CAUTION

Risk of burns. Beware of hot surfaces when using the heat gun.

- Shrink the tubes at a temperature of 275 °F / 135 °C.

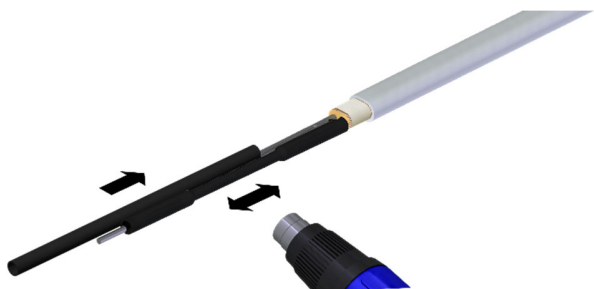

24

- Push the outer heat shrink tube (*length: 1" (25 mm); diameter: 1/2" (12 mm)*) over the end of the trace heater.
- Shrink the tube at a temperature of 275 °F / 135 °C.
- While still hot, compress the tube between the bus wires using pliers and hold for 5 seconds.

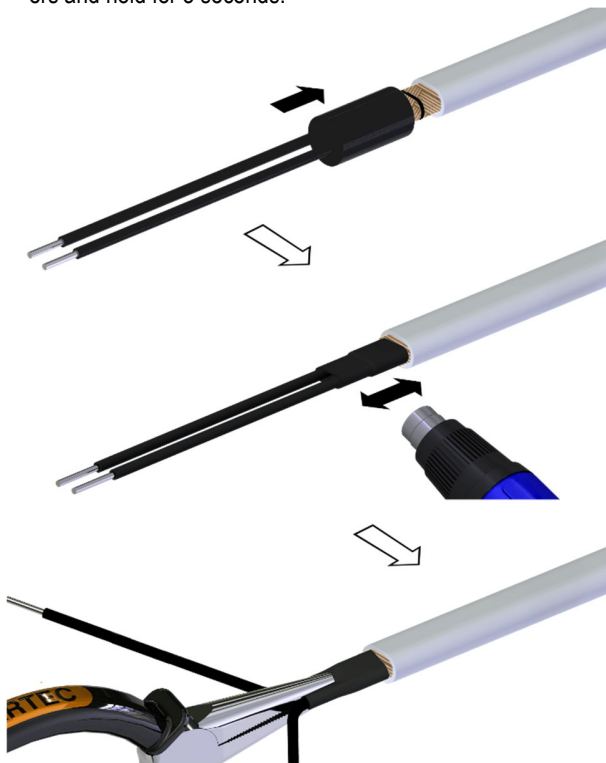

25

- Slide the bonding clip onto the trace heater(s).

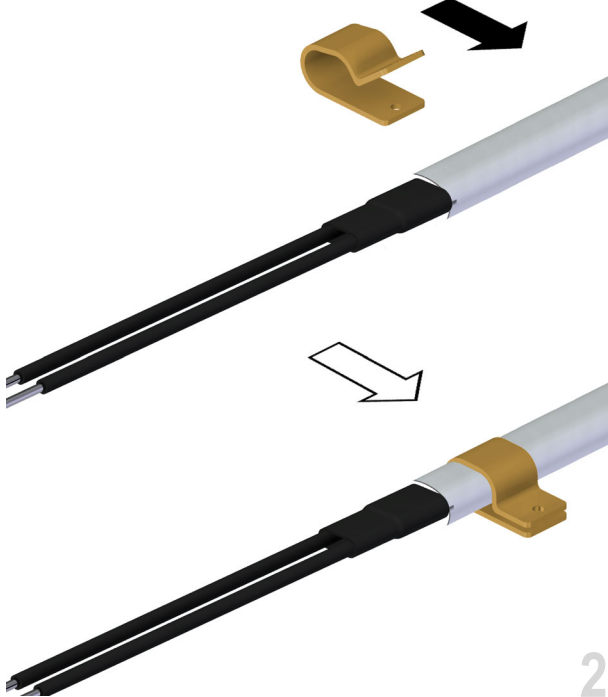

26

- Install the bonding jumper at the bonding clip.
- Install the fixing screw, the washer and the nut.
- Tighten the fixing screw using a flat screwdriver. Lock the counter nut using an adjustable wrench.

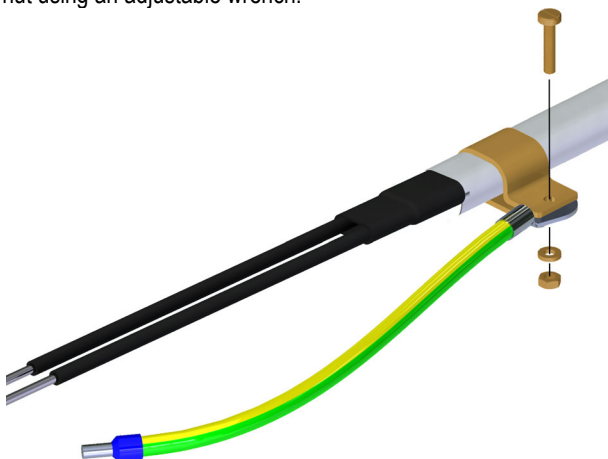

27

- Pull back the trace heater. For easy cable connection it is enough when the silicone pants stands out of the mounting stand.

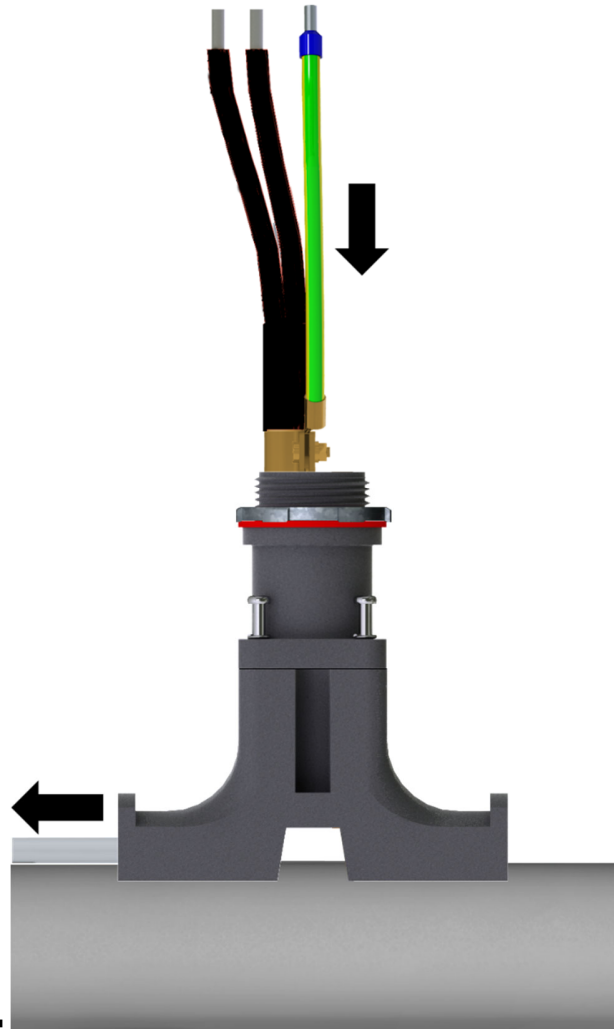

28

- Now, tighten the 4 fixing screws of the top unit of the mounting stand using a 3 mm hex wrench.



29

- Unscrew the lock nut of the top unit of the mounting stand.
- Feed the prepared trace heater into the junction box.
- Slide the junction box onto the top unit of the mounting stand.
- Install the lock nut and tighten it using tongue and groove pliers.

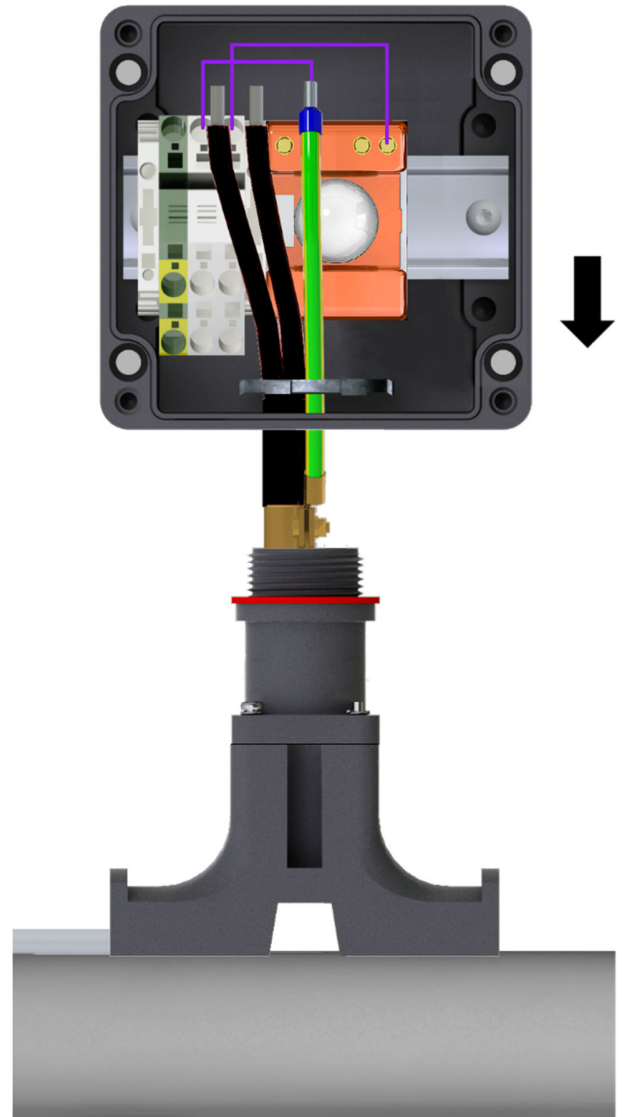

30

Wiring

- For wire connection at the terminals insert a small screwdriver into the screwdriver slot, then insert the wire.
- Connect all wires as shown.

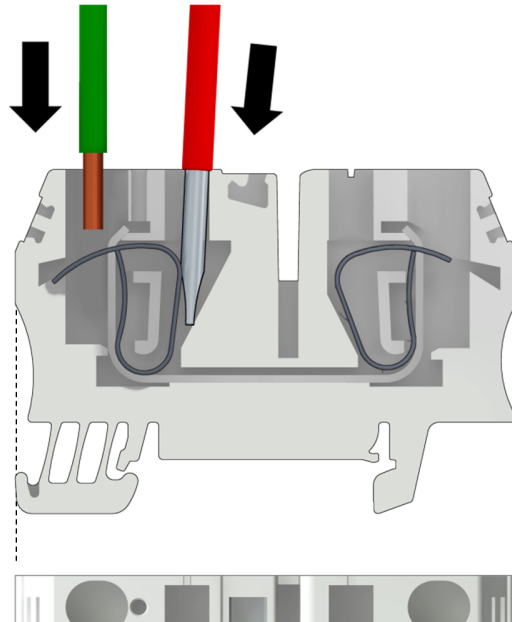

Power connection wiring:

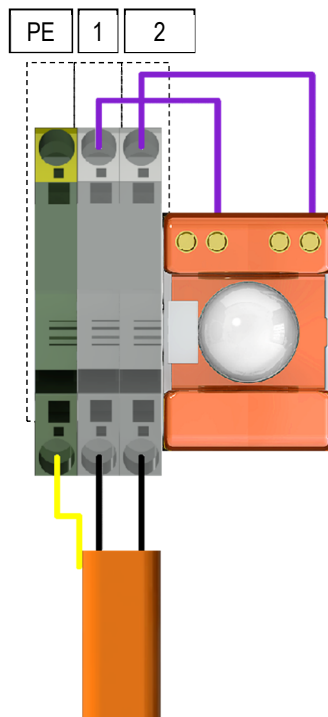

- Mount the cover of the junction box and tighten the 4 fixing screws using a screwdriver.

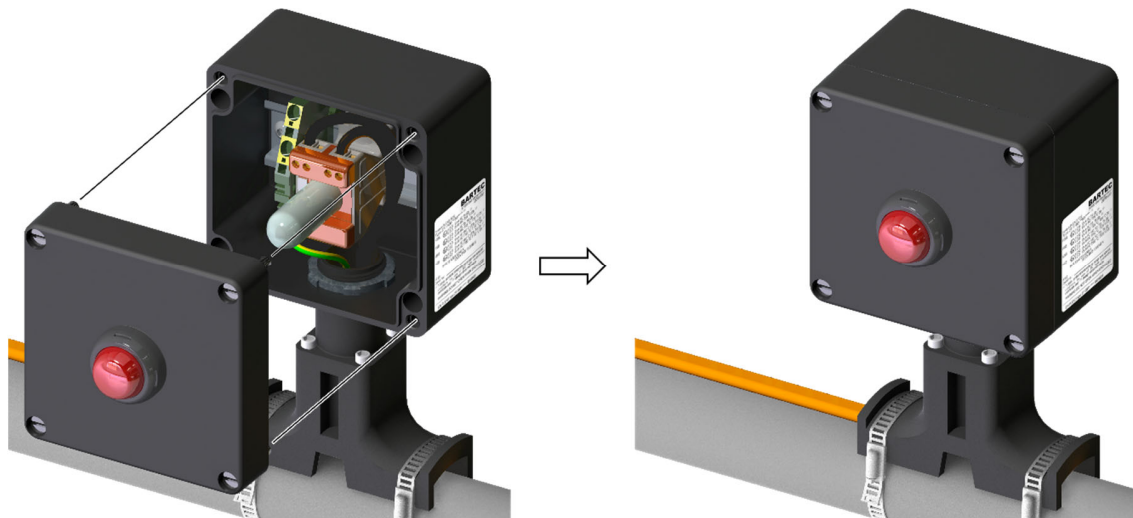

32

Application of the pipe insulation

- Apply the pipe insulation according to the manufacturer's installation instructions.
- Apply an electrical warning label every 10 ft. (3 m) on a clearly visible place.

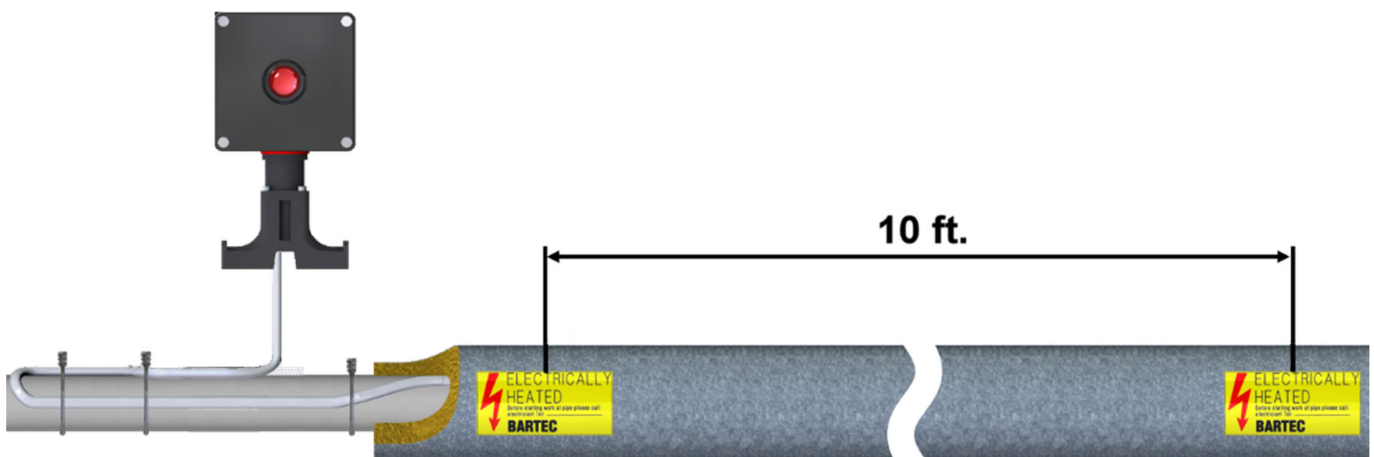

Tests and commissioning

Measurement of the insulation resistance

The measurement of the insulation resistance is used to determine damage to the trace heater and possible installation faults. It must be carried out at the following times:

- Preliminary test (on the reel, before installation of the trace heater on the construction site)
- Acceptance test (after installation of the heating circuit and before installation of the thermal insulation)
- Final inspection (immediately after completion of work on the thermal insulation)
- Upon commissioning
- Before switching on the installation

Preparation of the measurement:

- De-energize the heating circuit.
- Disconnect the thermostat or controller, if installed.
- Disconnect the bus wires and PE wires from the terminal block, if installed.
- For the measurement you will need a megohmmeter with, at least, a minimum testing voltage of 500 Vdc and a maximum testing voltage of 1000 Vdc.

Test 1 - Conducting the measurement between the bus wires and the aluminum jacket:

- Set the test voltage to 0 Vdc.
- Connect the negative (-) lead to the aluminum jacket of the trace heater.
- Connect the positive (+) lead to both trace heater bus wires simultaneously.
- Turn on the megohmmeter and set the voltage to 500 Vdc.
- Apply the voltage for 1 minute. The meter reading should stabilize. Rapid changes in the reading indicate a breakdown of the insulation.
- Record the insulation resistance value in the Inspection Record.
- Repeat the measurement at 1000 Vdc.

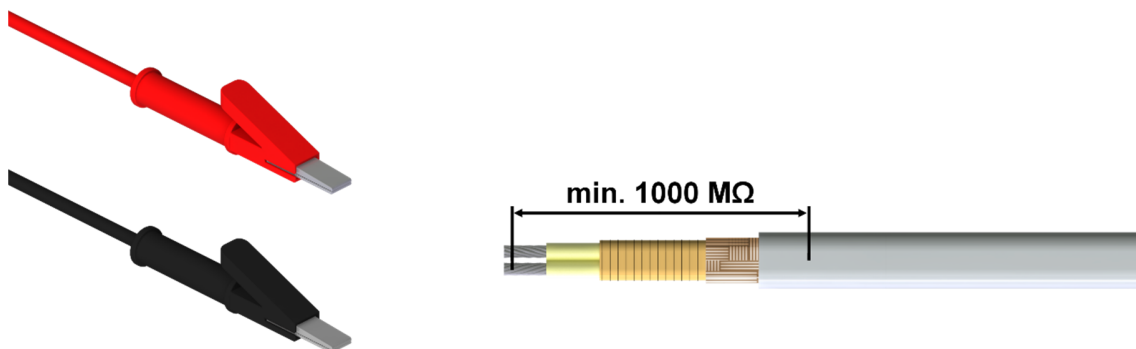

Results:

- Properly installed dry and clean trace heater sets should measure thousands of megohms, regardless of the trace heater length or measuring voltage (0-1000 Vdc). Even if optimum conditions may not apply, all insulation resistance values should be greater than the IEC 60079-30.1:2015 minimum recommendation of 20 megohms. However, BARTEC strongly recommends a minimum reading of 1000 megohms. If the reading is lower or fluctuating, refer to section *Troubleshooting* on the next page.
- Insulation resistance values for any particular circuit, should not vary more than 25 percent as a function of measuring voltage. Greater variances may indicate a problem with your trace heating system. Confirm proper installation and/or contact your local BARTEC representative for assistance.

⚠ WARNING

Risk of fire or electrical shock. If the insulation resistance is insufficient you must fix the heating circuit before putting it into operation.

After the measurement:

If trace heater meets all resistance criteria:

- Reconnect the bus wires.
- Reconnect any thermostat or controller.
- Reenergize the circuit.

Troubleshooting		
Problem	Possible cause	Remedy
Trace heater remains cold	No power supply	Check the power wiring for continuity to circuit breaker.
	Trace heater bus wires or power wiring not properly connected	Connect the trace heater and power wires according to the installation instructions.
	Control unit adjusted incorrectly	Adjust the control unit according to the installation instructions.
Automatic circuit breaker tripped	Automatic circuit breaker defective	Replace the automatic circuit breaker.
	Automatic circuit breaker has wrong tripping characteristics, e. g. "B" instead of "C"	Install an automatic circuit breaker with Type-C tripping characteristics or contact the factory for Type-B tripping characteristics.
	Nominal circuit breaker size is insufficient	Install an automatic circuit breaker with higher capacity. Observe the maximum amperage of all components of the trace heating circuit.
	Maximum heating circuit length has been exceeded	Split the heating circuit into separate circuits.
	End seal has not been installed	Install the end seal according to the installation instructions.
	Short circuit	Identify the cause and remedy the fault (e. g. ensure that trace heater bus wires are not twisted together).
	Humidity inside the connection system or end seal	Dry the components. For junction boxes, be sure that the conduit drain is installed and breathing properly.
Ground fault protection is disengaged	Trace heater damaged	Replace the trace heater at the point where it is damaged.
	Moisture in the components	Dry the components. For junction boxes, be sure that the conduit drain is installed and breathing properly.
	Ground fault protection defective	Replace the ground fault protection device(s).
Low or inconsistent insulation resistance	Trace heater damaged	Replace the trace heater at the point where it is damaged.
	Moisture in the components	Dry the components. For junction boxes, be sure that the conduit drain is installed and breathing properly.
	Arcing due to damaged trace heater insulation	Replace the trace heater at the point where it is damaged.
	Arcing due to inadequate stripping distance between heating element and grounding braid	Check the stripping distance between bus wires/heating element and grounding braid at all power, splice and end seal connections to ensure adequate separation.
	Short-circuit between the grounding braid and the heating element or the grounding braid and the pipe	Check for cut or damaged cable or inadequate stripping length.
	Test leads touching the junction box	Relocate test leads and retest.

Note: High pipe temperature may lower the insulation resistance reading relative to earlier readings on a cold pipe.

Alternate method for node location

- Score around the aluminium jacket at 3/4" (20 mm) from the end of the trace heater.

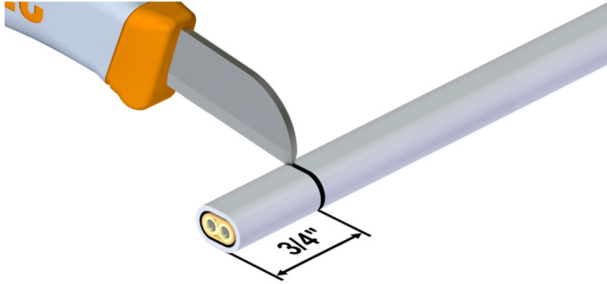

1

- Gently bend the aluminium jacket up and down at the scoring line using needle nose pliers until the aluminium jacket separates.

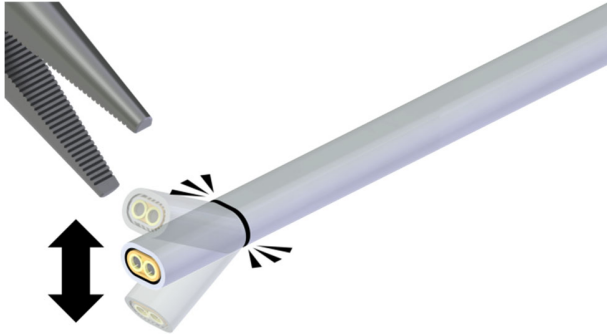

2

- Slide the aluminium jacket from the trace heater.

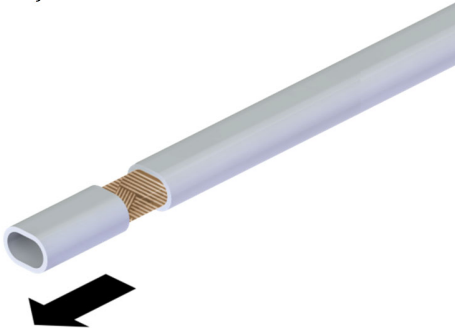

3

- Unwrap and cut off the outer insulation layer to expose the heating element.

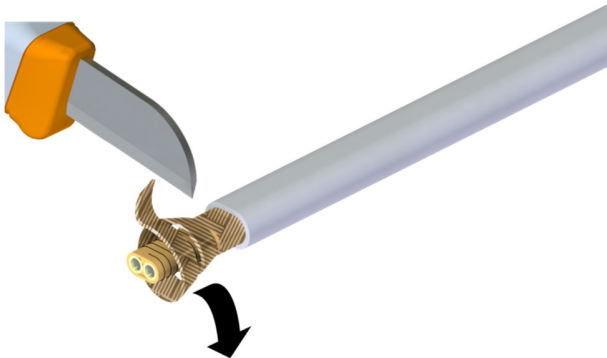

4

- Unravel 4-5 spirals of the heating element from around the inner insulation layer.

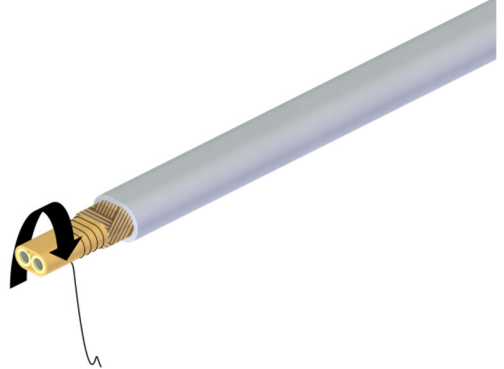

5

- Score around and along the middle of the bared inner insulation layer.
- Unwrap the inner insulation layer and bus wire insulation and cut it off to expose both bus wires.

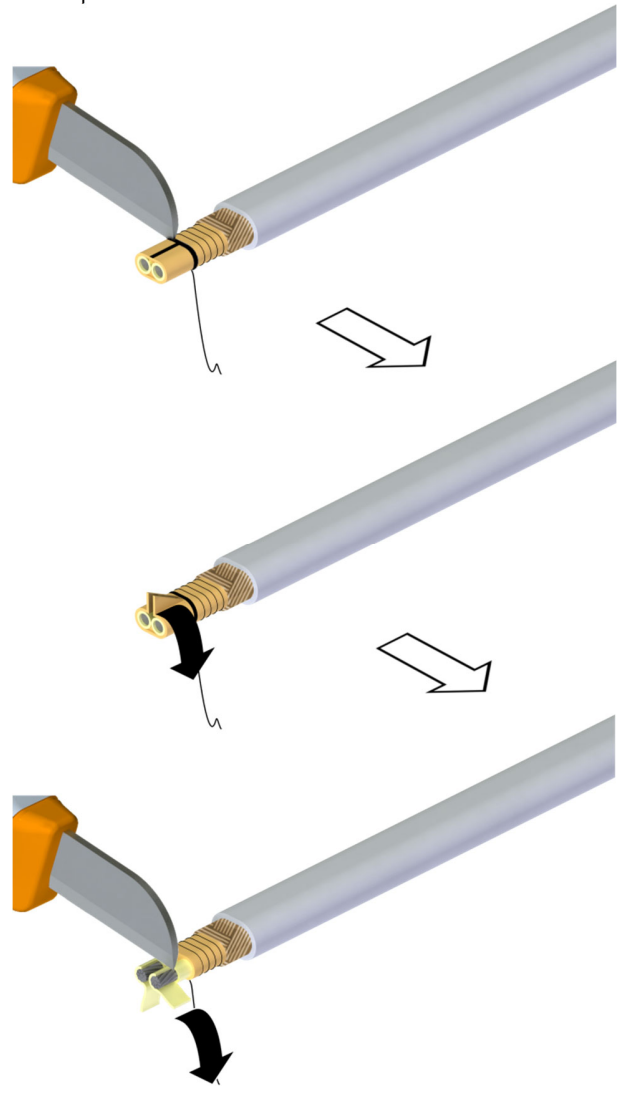

6

Alternate method for node location – only required if you cannot identify the node marker asterisks (*****) on the trace heater

- Using a standard multimeter, subsequently measure the resistance of each of the bus wires against the heating element.
- One of the 2 bus wires will display a much lower resistance.
- Note this lower reading.

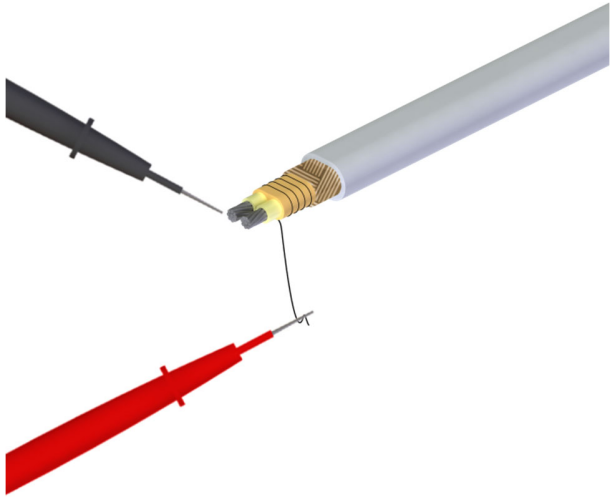

7

- You can now determine the distance between the trace heater end and the next node by referring to the respective product chart.
- For the product charts see section *Product charts for node location* beginning on page 23.

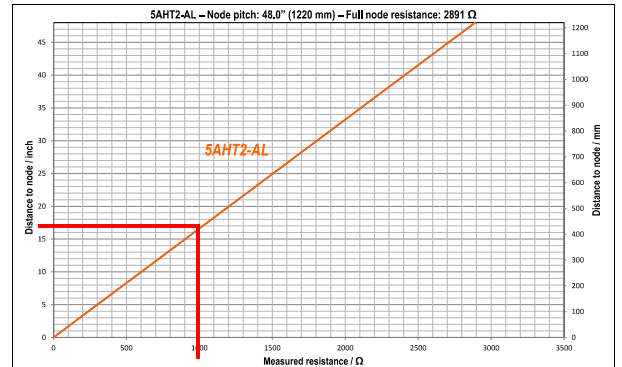

→ **Example**

- Measured resistance: **1000 Ω**
- Trace heater type: **5BPL2-AL**
- Full node resistance: **2891 Ω**
- Node pitch: **48"**

Distance to the next node: $1000 \Omega / 2891 \Omega \times 48'' = 17''$

8

- Using a tape measure, you can now locate the next node from the end of the trace heater.
- The distance between further nodes is the node pitch that you can also obtain in the product chart.

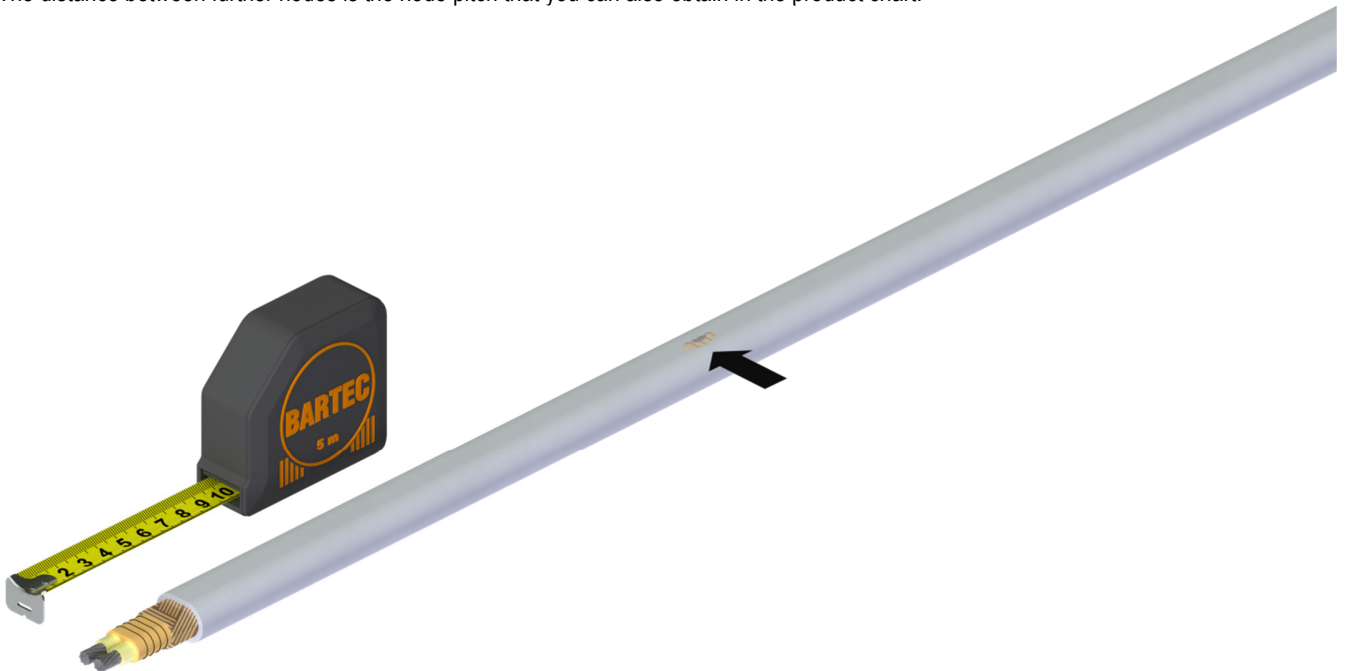

Once you have located the node position, you can continue with Step 6 on page 9.

9

Product charts for node location

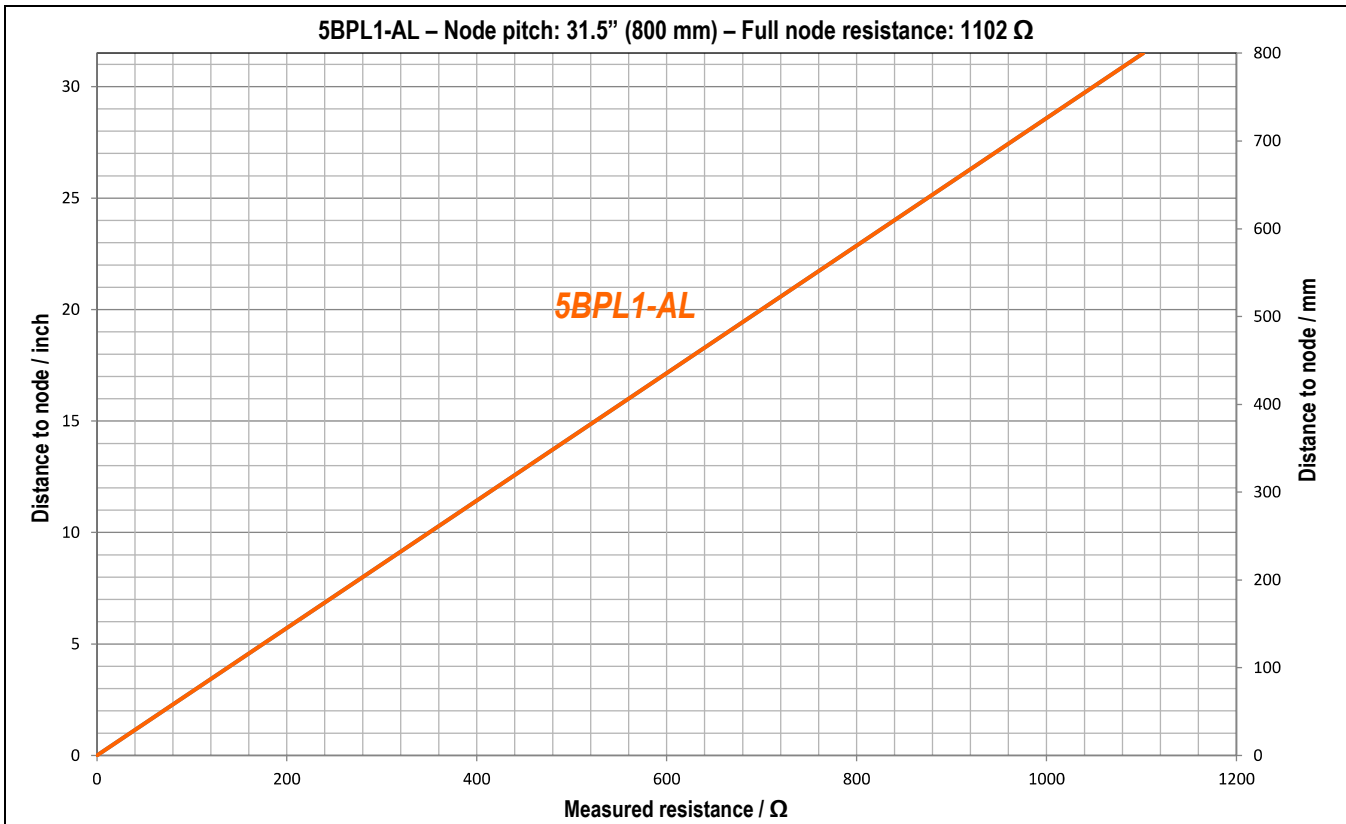

Product charts for node location

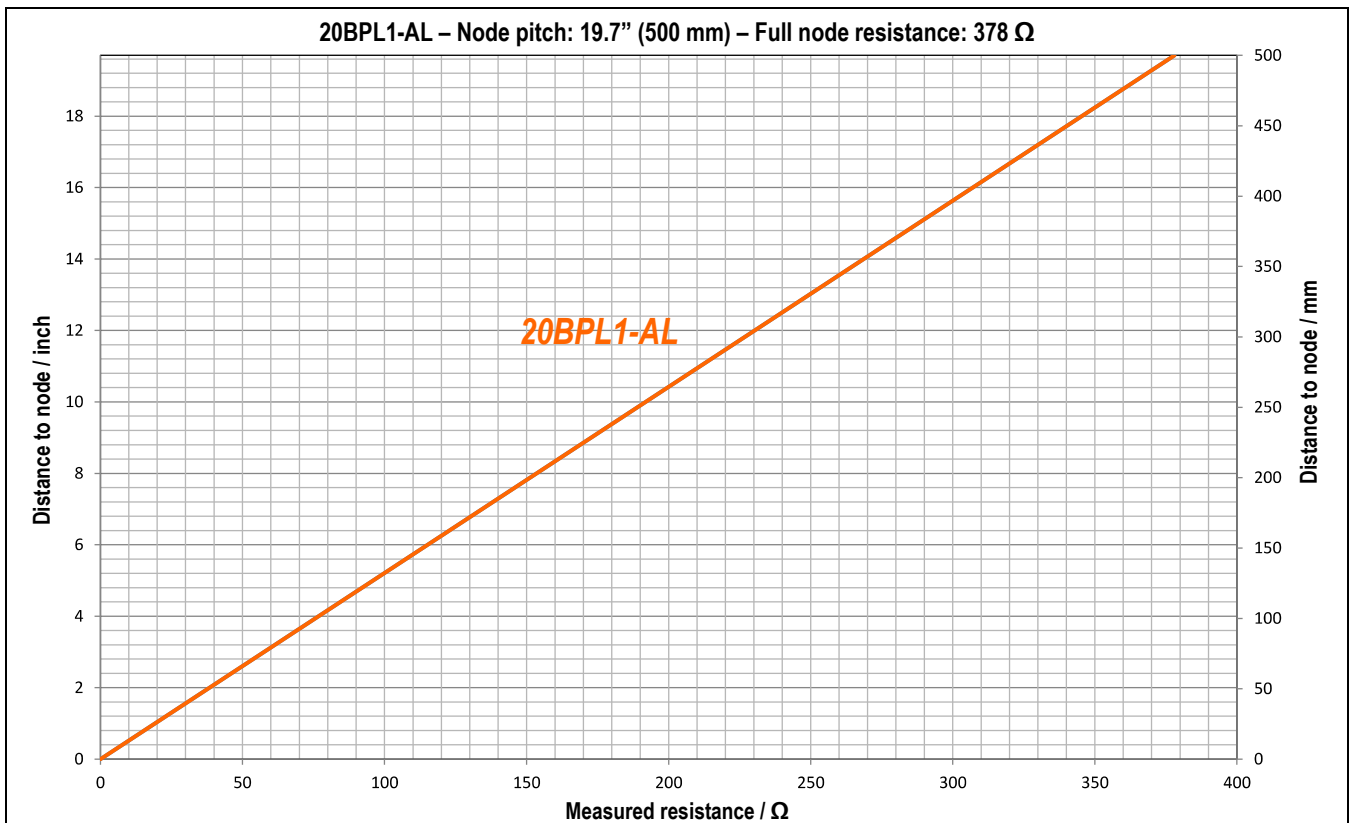
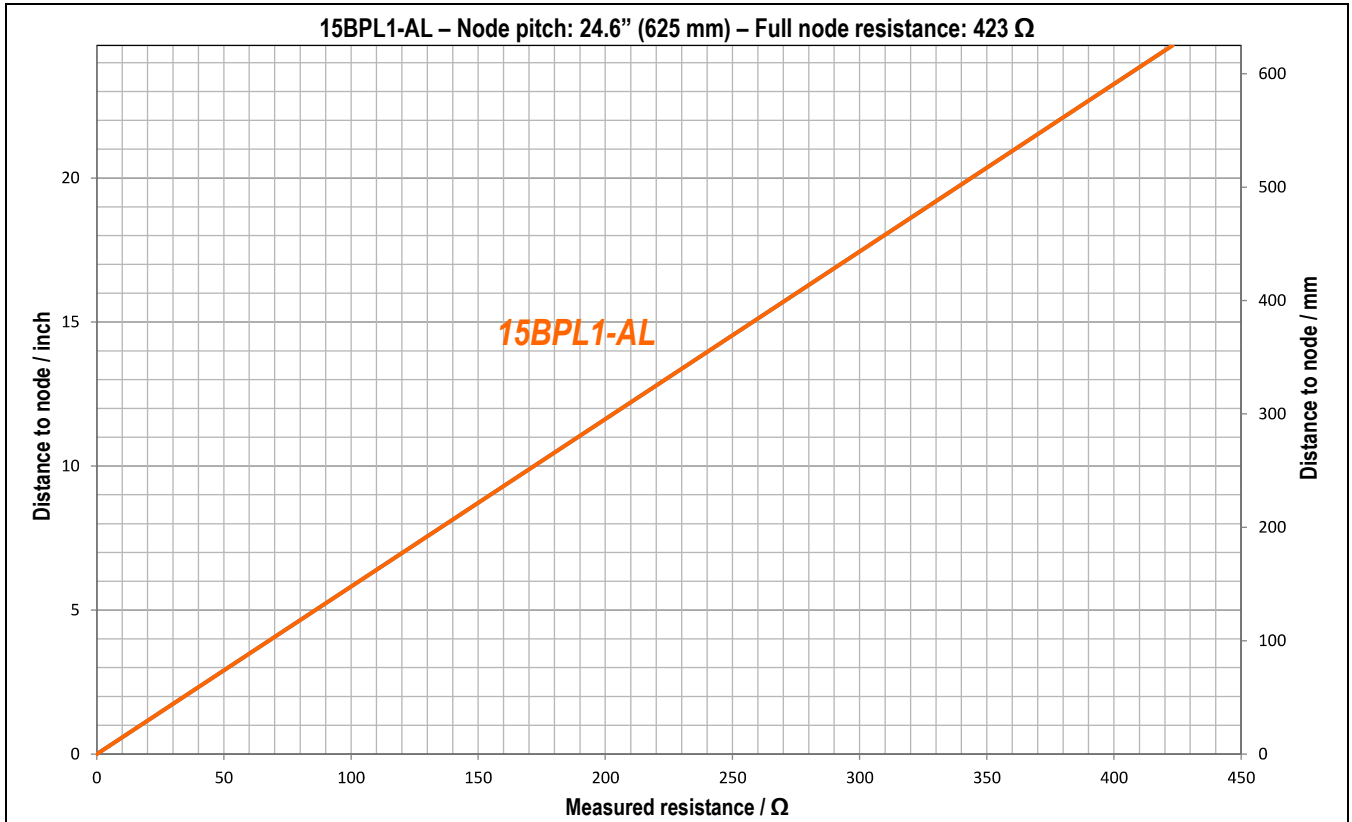

Product charts for node location

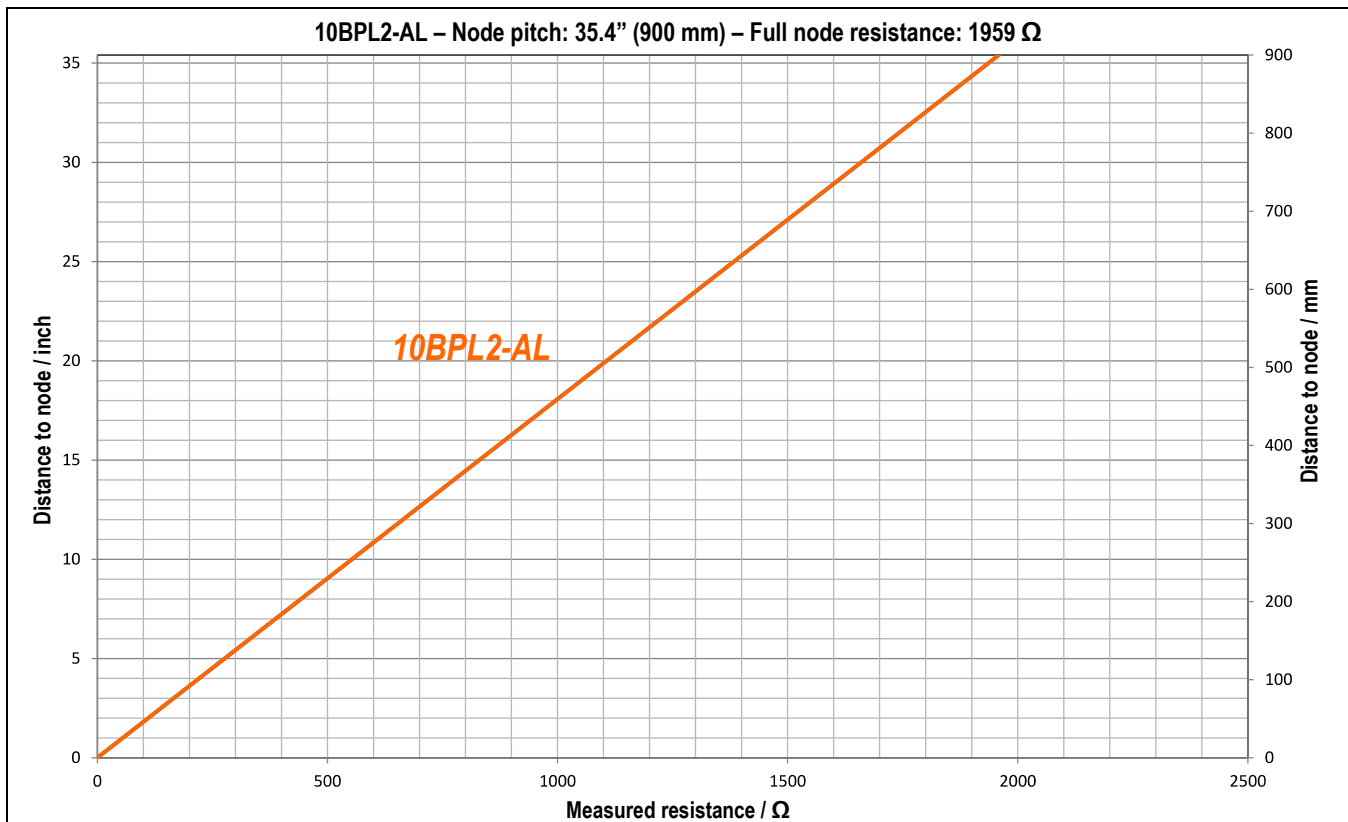
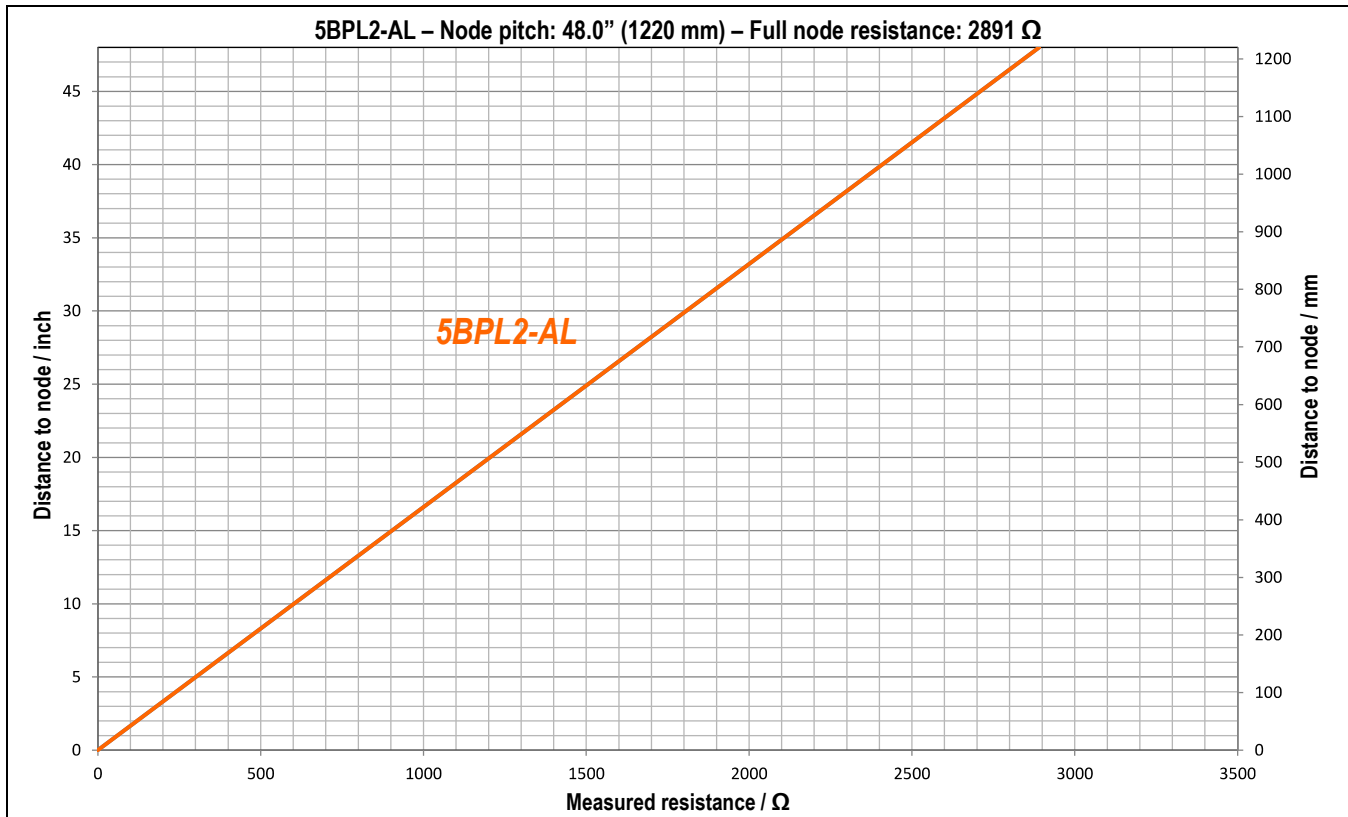

Product charts for node location

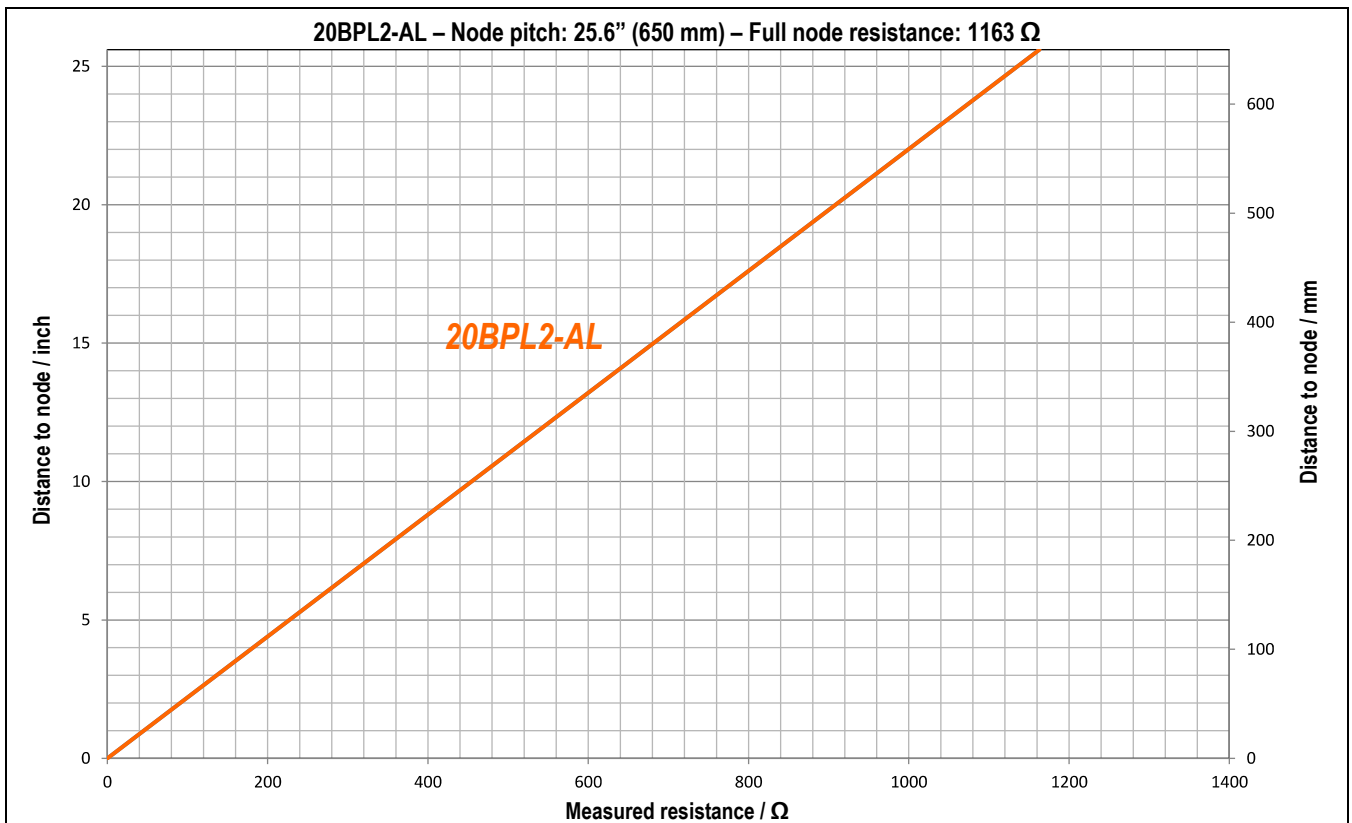
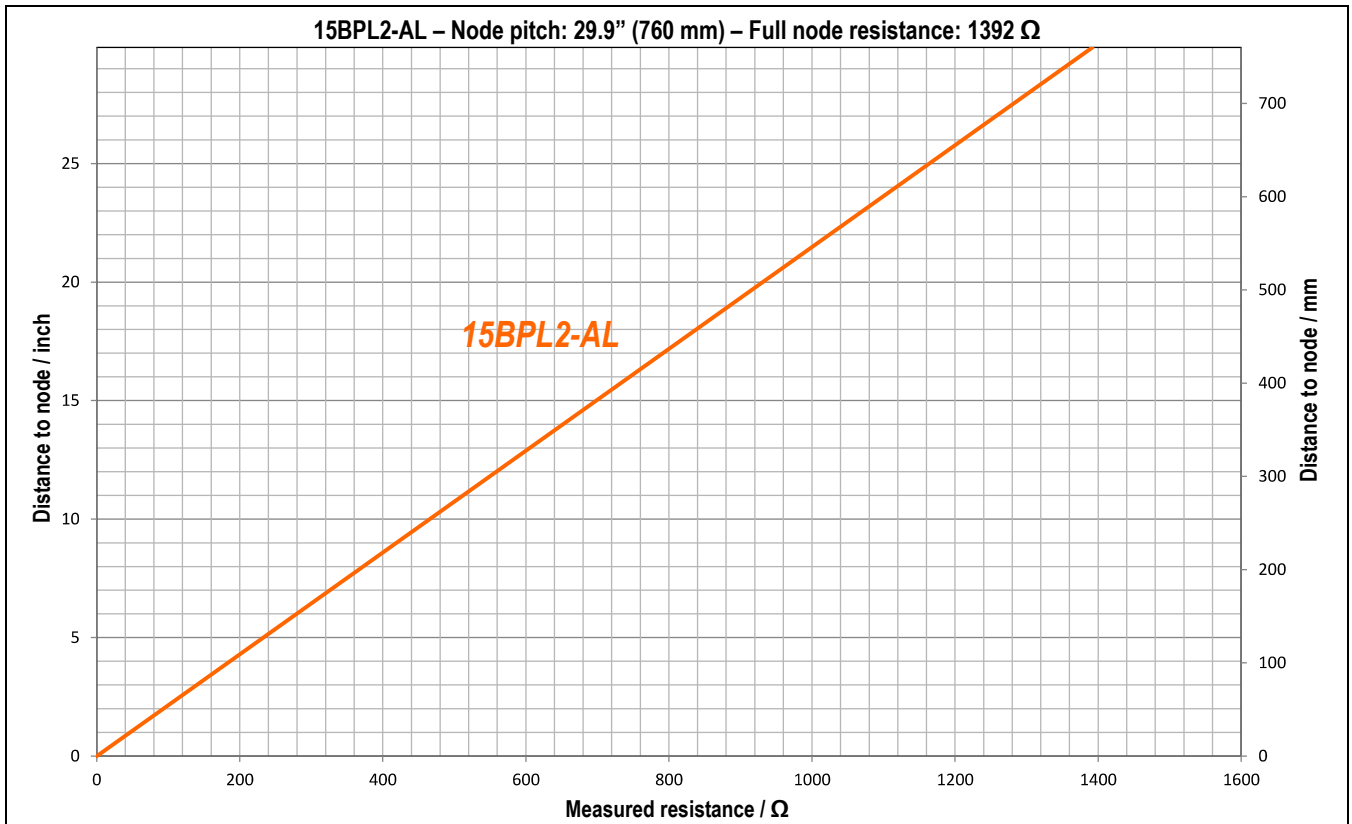

Limited Product warranty

Scope

BARTEC warrants that all BARTEC products and accessories that are the subject of this manual will be free from defects in materials and workmanship from and after its date of purchase for a period of two (2) years.

For the avoidance of doubt, this limited product warranty will **not** cover any damage caused by:

- accidents,
- misuse, improper installation, operation, maintenance or repairs,
- neglect, or
- alteration.

Furthermore, BARTEC cannot be held liable under this warranty for:

- installation or removal costs,
- loss or damage to property,
- indirect, special, incidental or consequential damages (including, without limitation, loss of revenue or anticipated profits), or
- any other damages or costs directly or indirectly related to the warranty issue.

If all warranty conditions are met (as set forth below), BARTEC will, at its sole discretion:

- repair the product,
- replace the product, or
- refund the purchase price paid for the product.

This warranty gives you specific legal rights, and you may also have other rights which vary by country, state or province. Except as specifically provided otherwise in this limited product warranty, the BARTEC US general terms and conditions shall apply.

Conditions

The limited product warranty is subject to the following conditions:

- proper installation, operation and maintenance in compliance with the state of the technology and the product documentation, and
- presence of completely filled in acceptance reports for all installation, maintenance and repairwork operations.

How to claim the warranty

To file a claim under the limited product warranty:

- Notify BARTEC or your local BARTEC representative by written correspondence or email within 30 days after identification of a possible warranty issue.
- If requested, you must provide any warranty-related information and documentation to BARTEC, including, without limitation:
 - project planning documents, and
 - acceptance reports for installation, operation, maintenance or repairwork.

Applicability of implied warranties, state or provincial laws

BARTEC HEREBY DISCLAIMS, TO THE FULL EXTENT POSSIBLE UNDER APPLICABLE LAW, (I) ALL OTHER WARRANTIES, EXPRESS OR IMPLIED, INCLUDING WITHOUT LIMITATION ANY IMPLIED WARRANTY OF MERCHANTABILITY, FITNESS FOR A PARTICULAR PURPOSE OR USE OR FREEDOM FROM INFRINGEMENT OR THIRD PARTY INTELLECTUAL PROPERTY RIGHTS, OR ARISING FROM COURSE OF DEALING, COURSE OF PERFORMANCE OR USAGE OF TRADE, AND (II) ANY OTHER OBLIGATION OR LIABILITY ON THE PART OF BARTEC MANAGEMENT, IN EACH CASE, WHETHER BASED ON STATUTE, CONTRACT, STRICT LIABILITY, TORT OR ANY OTHER LEGAL THEORY AND IRRESPECTIVE OF WHETHER BARTEC HAS ADVANCE NOTICE OF THE POSSIBILITY OF SUCH DAMAGES. BARTEC'S RESPONSIBILITY TO REPAIR, REPLACE, OR OFFER A REFUND FOR BARTEC PRODUCTS AND ACCESSORIES THAT ARE THE SUBJECT OF THIS MANUAL IS THE SOLE AND EXCLUSIVE REMEDY PROVIDED TO THE CUSTOMER FOR BREACH OF THE WARRANTY PROVIDED HEREIN.

Some countries, states and provinces do not allow the exclusion or limitation of incidental or consequential damages or exclusions or limitations on implied warranties, so the above limitations may not apply to you.

Contact

Bartec US, 650 Century Plaza Drive, Suite D120, Houston, Texas 77073, USA
Phone: +1 281 214-8542, Fax: +1 281 241-8547
sales@bartec.us, www.bartec.us

BARTEC REGIONAL OFFICES

BARTEC GERMANY

BARTEC Vertrieb Deutschland GmbH
Max-Eyth-Straße 16
97980 BAD MERGENTHEIM, Germany
Tel.: +49-79 31-597 0
Fax: +49-79 31-597 119
info@bartec.com
www.bartec.com

BARTEC AUSTRIA

BARTEC Elektrotechnik GmbH
Brown Boveri Straße 8/2/1
2351 WIENER NEUDORF, Austria
Tel.: +43-2236-212 040
Fax: +43-2236-212 04 99
office@bartec.at
www.bartec.com

BARTEC NORWAY

BARTEC Technor AS
Vestre Svanholmen 24
4313 SANDNES, Norway
+47 51 84 41 00
+47 51 84 41 01
www.bartec-technor.no
sales@bartec-technor.no

BARTEC MIDDLE EAST

BARTEC Middle East
HB-01, Near Round About 8,
Jebel Ali Free Zone
P.O. Box 17830, DUBAI,
United Arab Emirates
Tel.: +971 4 8876 162
Fax: +971 4 8876 182
bartec@bartec.ae
www.bartec.com

BARTEC FRANCE

BARTEC France
20, rue de l'industrie
BP 80420 Fegersheim
67412 ILLKIRCH CEDEX, France
Tel.: +33 3 88-59 03 05
Fax: +33 3 88-64 34 11
info@bartec.fr
www.bartec.fr

BARTEC US

BARTEC US Corp.
650 Century Plaza Drive
Suite D120
HOUSTON TX 77073, USA
Tel.: +1 281 214 8542
Fax: +1 281 214 8547
sales@bartec.us
www.bartec.us

BARTEC NETHERLANDS

BARTEC NEDERLAND b.v.
Boelewerf 25
2987 VD RIDDERKERK, The Netherlands
Tel.: +31-180-41 05 88
info@bartec.nl
www.bartec.nl

BARTEC ITALY

BARTEC S.r.l.
Via per Carpiano, 8/10
20077 MELEGNANO (Mi), Italy
Tel.: +39-02-92 27 78 00
Fax: +39-02-98 23 19 96
info@bartec.it
www.bartec.it

BARTEC SWEDEN (& DK, FI, LT, LV, EE)

BARTEC AB
Tennvägen 1
371 50 KARLSKRONA, Sweden
Tel.: +46 455 68 74 00
Tel.: +45 8988 1112 (for DK)
info@bartec.se
www.bartec.se

BARTEC SAUDI ARABIA

Bartec MIDDLE EAST LLC
31952 AL KHOBER P.O Box 3685
Kingdom of Saudi Arabia
Tel.: + 966 13 823 8101
Fax: + 966 13 823 8102
fahad.khan@bartec.de
www.bartec.com

BARTEC KOREA

BARTEC Ltd, Korea
C-601, 168, Gasandigital 1-ro,
Geumcheon-gu, Seoul, Korea
Tel.: +82 2 2631 4271
Fax: +82 2 6264 1609
info@bartec.co.kr
www.bartec.com

BARTEC CHINA

BARTEC Explosion Proof Appliances
(Shanghai) Co. Ltd.
New Building 7, No. 188 Xinjun Ring Road
Caohejing Pujiang Hi-Tech Park
(Pudong Area), Minhang District
201114 SHANGHAI, China
Tel.: +86 21 34637288
Fax: +86 21 34637282
info@bartec.com.cn
www.bartec.com.cn

BARTEC BELGIUM

BARTEC Belgium N. V.
H. Hartlaan 26,
Industriepark Schoonhees West Zone 1
3980 TESSENDERLO, Belgium
Tel.: +32-13-67 23 08
info@bartec.be
www.bartec.be

BARTEC UK

BARTEC (UK) Ltd.
Arundel House, Little 66
Hollins Brook Park, Pilsworth Road
BURY BL9 8RN, United Kingdom
Tel.: +44-8444 992 710
Int Tel.: +44 161 767 1590
Fax: +44-8444 992 715
Int Fax: +44 161 767 1591
info@bartec.co.uk
www.bartec.co.uk

BARTEC RUSSIA

OOO „BARTEC Rus“
5A, bld. 1 Volkovskoe Shosse
“Volkvovsky” Business Center, Office 401
141006, MYTISCHI, MOSCOW REGION
Russia
Tel. + Fax: +7 495 249 0542
mail@bartec-russia.ru
www.bartec-russia.ru

BARTEC INDIA

BARTEC India Pvt. Ltd.
C-56 /45, 1st Floor-Priska Tower,
Sector-62 NOIDA-201309, U.P, INDIA
Tel.: +91 120 4523 200
Fax: +91 120 4523 264
E-mail: info.bartecindia@bartec.in
www.bartec.com

BARTEC LATIN AMERICA

BARTEC LATAM SAS
Calle 106 # 54-78
Oficina 402, Torre Empresarial Baikal
BOGOTA D.C., Colombia
Tel.: +57 (1) 7035 146 (Sales)
Tel.: +57 (1) 7559 301 (Admin)
info@bartec.com.co
www.bartec.com.co

BARTEC ASIA PACIFIC

BARTEC Pte Ltd
63 Hillview Avenue
07-20/21 Lam Soon Building
SINGAPORE 669569
Tel.: +65-6 7625030
Fax: +65-6 7625031
info@bartecasia.com
www.bartecasia.com

BARTEC GmbH
Max-Eyth-Straße 16
97980 Bad Mergentheim
Germany

Phone: +49 7931 597-0
Fax: +49 7931 597-499
info@bartec.com
www.bartec.com

BARTEC US
650 Century Plaza Drive, Suite D120
Houston, Texas
USA

Phone: +1 281 214-8542
Fax: +1 281 214-8547
info@bartec.us
www.bartec.us